

HNC Electric Limited

Tel: + 86 20 84898493
Email: info@hncelectric.com
Website: www.hncelectric.com
Address: No. 9, Fucai Road, Longyou Chengbei Industrial Zone, Quzhou, Zhenjiang Province, PRC

Precise Planet Gear Box

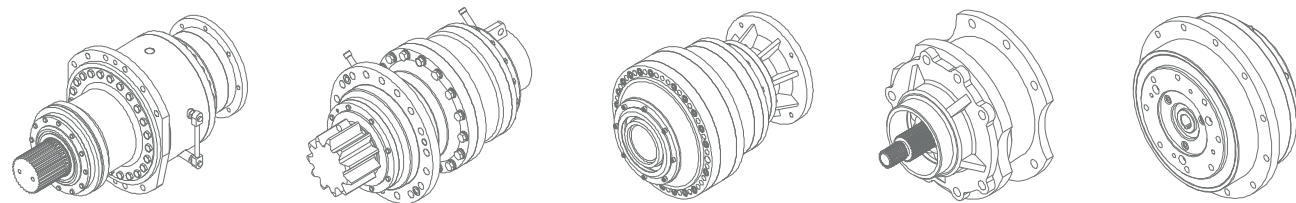



Series of products	01
Reducer type description	02
The special terminology	03
Reducer Selection Guide	05

Dimensions and technical parameters of reducer is installed

PLE060 series	07
PLF060 series	08
PLS060 series	09
ZPLE060series	10
ZPLF060series	11
PLH060 series	12
PLE090 series	13
PLF090 series	14
PLS090 series	15
ZPLE090series	16
ZPLF090series	17
PLH090 series	18
PLE120 series	19
PLF120 series	20
PLS120 series	21
ZPLE120series	22
ZPLF120series	23
PLH120 series	24
PLE160 series	25
PLF160 series	26
PLS160 series	27
ZPLE160series	28
ZPLE160series	29
PLH160 series	30
AB precision planetary gear outline drawing	31-38
V series precision spiral bevel gear box	39-45
Reducer installation	46

PLE series reducer (PLE060 PLE090 PLE120 PLE160)

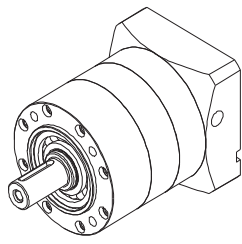

4 optional size	60mm, 90mm, 120mm, 160mm	
Rated output torque	8.5Nm~680.0Nm	
Ratio	1-stage	3, 4, 5, 7, 10
	2-stage	12, 16, 20, 25, 28, 35, 40, 50, 70, 100
	3-stage	80, 100, 125, 140, 175, 200, 250, 350, 400, 500, 700, 1000
backlash	1-stage	Precision: <3 arc-min Standard: <8 arc-min
	2-stage	Precision: <5 arc-min Standard: <10 arc-min
	3-stage	Precision: <8 arc-min Standard: <12 arc-min

PLF series reducer (PLF060 PLF090 PLF120 PLF160)

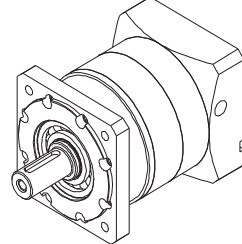

4 optional size	60mm, 90mm, 120mm, 160mm	
Rated output torque	8.5Nm~680.0Nm	
Ratio	1-stage	3, 4, 5, 7, 10
	2-stage	12, 16, 20, 25, 28, 35, 40, 50, 70, 100
	3-stage	80, 100, 125, 140, 175, 200, 250, 350, 400, 500, 700, 1000
backlash	1-stage	Precision: <3 arc-min Standard: <8 arc-min
	2-stage	Precision: <5 arc-min Standard: <10 arc-min
	3-stage	Precision: <8 arc-min Standard: <12 arc-min

PLS series reducer (PLS060 PLS090 PLS120 PLS160)

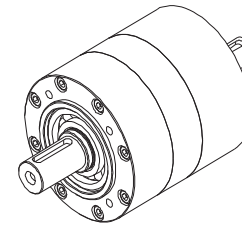

4 optional size	60mm, 90mm, 120mm, 160mm	
Rated output torque	8.5Nm~680.0Nm	
Ratio	1-stage	3, 4, 5, 7, 10
	2-stage	12, 16, 20, 25, 28, 35, 40, 50, 70, 100
	3-stage	80, 100, 125, 140, 175, 200, 250, 350, 400, 500, 700, 1000
backlash	1-stage	Precision: <3 arc-min Standard: <8 arc-min
	2-stage	Precision: <5 arc-min Standard: <10 arc-min
	3-stage	Precision: <8 arc-min Standard: <12 arc-min

PLH series reducer (PLH064 PLH090 PLH120 PLH160)

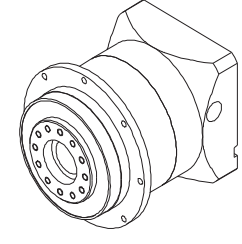

4 optional size	64mm, 90mm, 120mm, 160mm	
Rated output torque	8.5Nm~680.0Nm	
Ratio	1-stage	3, 4, 5, 7, 10
	2-stage	12, 16, 20, 25, 28, 35, 40, 50, 70, 100
	3-stage	80, 100, 125, 140, 175, 200, 250, 350, 400, 500, 700, 1000
backlash	1-stage	Precision: <3 arc-min Standard: <8 arc-min
	2-stage	Precision: <5 arc-min Standard: <10 arc-min
	3-stage	Precision: <8 arc-min Standard: <12 arc-min

ZPLE series reducer (ZPLE060 ZPLE090 ZPLE120 ZPLE160)

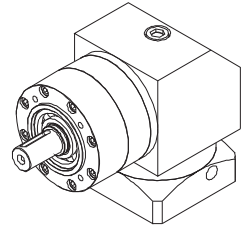

4 optional size	60mm, 90mm, 120mm, 160mm	
Rated output torque	8.5Nm~680.0Nm	
Ratio	1-stage	3, 4, 5, 7, 10
	2-stage	12, 16, 20, 25, 28, 35, 40, 50, 70, 100
	3-stage	80, 100, 125, 140, 175, 200, 250, 350, 400, 500, 700, 1000
backlash	1-stage	Precision: <3 arc-min Standard: <8 arc-min
	2-stage	Precision: <5 arc-min Standard: <10 arc-min
	3-stage	Precision: <8 arc-min Standard: <12 arc-min

ZPLF series reducer (ZPLF060 ZPLF090 ZPLF120 ZPLF160)

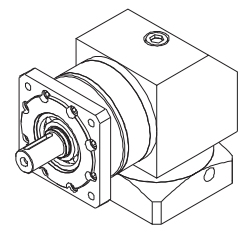

4 optional size	60mm, 90mm, 120mm, 160mm	
Rated output torque	8.5Nm~680.0Nm	
Ratio	1-stage	3, 4, 5, 7, 10
	2-stage	12, 16, 20, 25, 28, 35, 40, 50, 70, 100
	3-stage	80, 100, 125, 140, 175, 200, 250, 350, 400, 500, 700, 1000
backlash	1-stage	Precision: <3 arc-min Standard: <8 arc-min
	2-stage	Precision: <5 arc-min Standard: <10 arc-min
	3-stage	Precision: <8 arc-min Standard: <12 arc-min

AB series reducer (AB060 AB090 AB115 AB142 AB180 AB220 AB280 AB330 AB400)

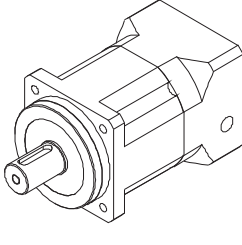

9 optional size	60mm, 90mm, 115mm, 140mm, 180mm, 220mm, 280mm, 330mm, 400mm	
Rated output torque	18.5Nm~9800.0Nm	
Ratio	1-stage	3, 4, 5, 7, 10
	2-stage	9, 15, 20, 25, 30, 35, 40, 50, 70, 1000
	3-stage	84, 80, 100, 150, 200, 250, 350, 400, 500, 700, 1000
backlash	1-stage	Precision: <4 arc-min Standard: <8 arc-min
	2-stage	Precision: <6 arc-min Standard: <10 arc-min
	3-stage	Precision: <7 arc-min Standard: <18 arc-min

ABR series reducer (ABR060 ABR090 ABR115 ABR142 ABR180 ABR220 ABR280)

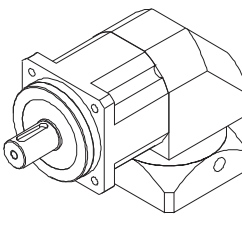

7 optional size	60mm, 90mm, 115mm, 140mm, 180mm, 220mm, 280mm	
Rated output torque	18.5Nm~5120.0Nm	
Ratio	1-stage	3, 4, 5, 7, 10
	2-stage	9, 15, 20, 25, 30, 35, 40, 50, 70, 1000
	3-stage	84, 80, 100, 150, 200, 250, 350, 400, 500, 700, 1000
backlash	1-stage	Precision: <5 arc-min Standard: <8 arc-min
	2-stage	Precision: <7 arc-min Standard: <10 arc-min
	3-stage	Precision: <9 arc-min Standard: <18 arc-min

VS series reducer (VS09 VS11 VS14 VS17 VS21 VS24 VS28)

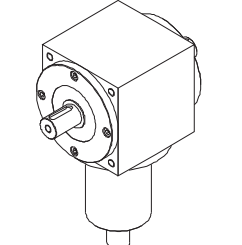

7 optional size	90mm, 110mm, 140mm, 170mm, 210mm, 240mm, 280mm	
The allowable input power	1.1KW~188KW	
Ratio	1, 1.5, 2, 3, 4, 5	

VA series reducer (VA09 VA11 VA14 VA17 VA21 VA24 VA28)

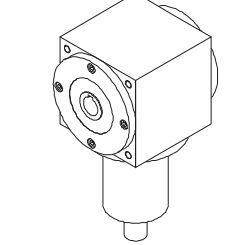

7 optional size	90mm, 110mm, 140mm, 170mm, 210mm, 240mm, 280mm	
The allowable input power	1.1KW~188KW	
Ratio	1, 1.5, 2, 3, 4, 5	

Reducer type description

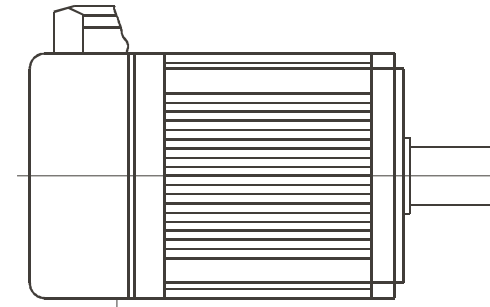

Motor data

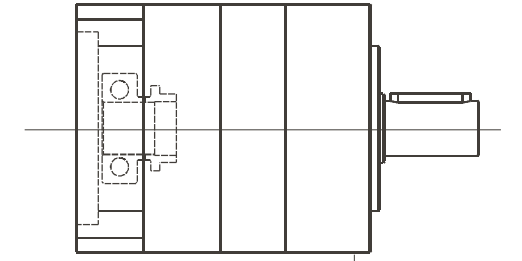

Reducer data

With the speed reducer, the need to provide the motor mounting dimension $\varnothing S \cdot LR / \varnothing LB \cdot LE / 4 - \varnothing LZ - \varnothing LA$. To check the rationality of the motor and reducer with performance, the need to provide more detailed parameters (such as the rated speed, rated torque, maximum torque)

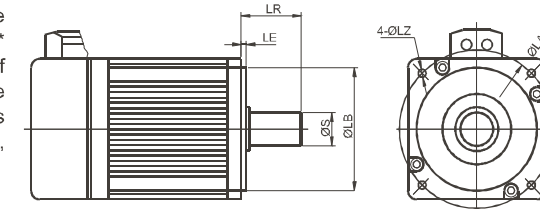

PLE060 - L1 - 5 - S2 - P2 - T / The motor size or drawings.

Reducer specifications According to the selection of products introduction	Stage L1: 1-stage L2: 2-stage L3: 3-stage	Ratio According to the choice of various models reducer technical parameters table	Output shaft S2: Shaft with keyway S1: Optical shaft K: hollow single shaft	Accuracy class P2: standard P1: precision P0: high precision	Special T	The motor size
---	--	---	--	---	--------------	----------------

Ordering specification for example :

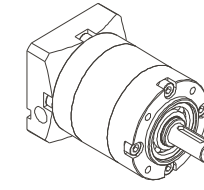

PLE060-L1-5-S2-P2 / $\varnothing 14 \cdot 30 / \varnothing 50 \cdot 3/4 - \varnothing 4.5 - \varnothing 70$

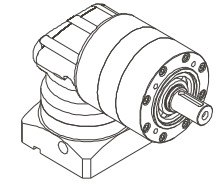

ZPLE090-L1-5-S2-P2 / $\varnothing 19 \cdot 40 / \varnothing 70 \cdot 3/4 - \varnothing 6.5 - \varnothing 90$

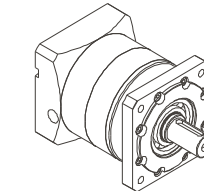

PLF090-L2-50-S1-P1 / $\varnothing 19 \cdot 40 / \varnothing 70 \cdot 3/4 - \varnothing 6.5 - \varnothing 90$

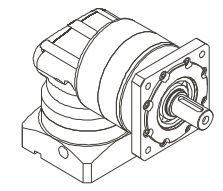

ZPLF090-L1-5-S1-P1 / $\varnothing 19 \cdot 40 / \varnothing 70 \cdot 3/4 - \varnothing 6.5 - \varnothing 90$

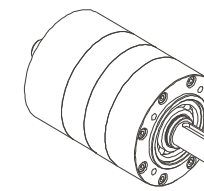

PLS090-L2-50-S2-P1

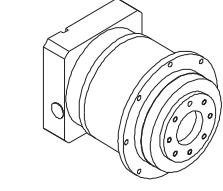

PLH120-L2-50-S2-P1 / $\varnothing 22 \cdot 55 / \varnothing 110 \cdot 3/4 - \varnothing 9 - \varnothing 145$

Speed reducer special terminology

Rated input speed n1[rpm]: The driving speed reducer, such as reducer and motor connected directly, the speed value is the same as the motor speed. In this book Rated input speed is at an ambient temperature of 20 °C measured under the condition of high temperature environment, reduce speed n1.

Output speed n2[rpm]: Output speed according to the following formula through the input speed of N1 and transmission ratio I calculated.

$$n_2 = \frac{n_1}{i}$$

The ratio of i: Said gear change three major parameters of a movement of value, namely through the reducer ratio to change the speed, torque and moment of inertia.

Rated output torque of TN[Nm]:The deceleration time (the continuous working system) can load torque (no wear), conditions should meet the uniform load, the safety coefficient S=1, the theoretical lifetime is 20000 hours; the value of T2N to comply with ISO DP 6336 and ISO 281 standard gear standard bearings.

Maximum torque of Tmax[Nm]: The speed reducer under static conditions or high output torque can afford to stop condition. Usually the peak load or starting load. (Tmax=2 · TN)

The actual torque of Ts[Nm]: The actual working conditions required torque depends on the application. The rated torque TN reducer must be greater than the torque.

Calculated by the torque of Tc[Nm]: Will be used in the selection of speed reducer, can Ts torque and coefficient of FS required by the actual, according to the following formula

$$T_c = T_s \cdot f_s \leq T_N$$

Effective rate η: The ratio of output power to input power. Due to the power loss due to friction makes the efficiency is always less than 1 (100%), the efficiency of labeled samples is reducer at full load movement were measured. The smaller the input power and torque are smaller, efficiency is lower, this is because the idling torque is constant. At this time, the power loss is not improved. Speed will also affect the efficiency of.

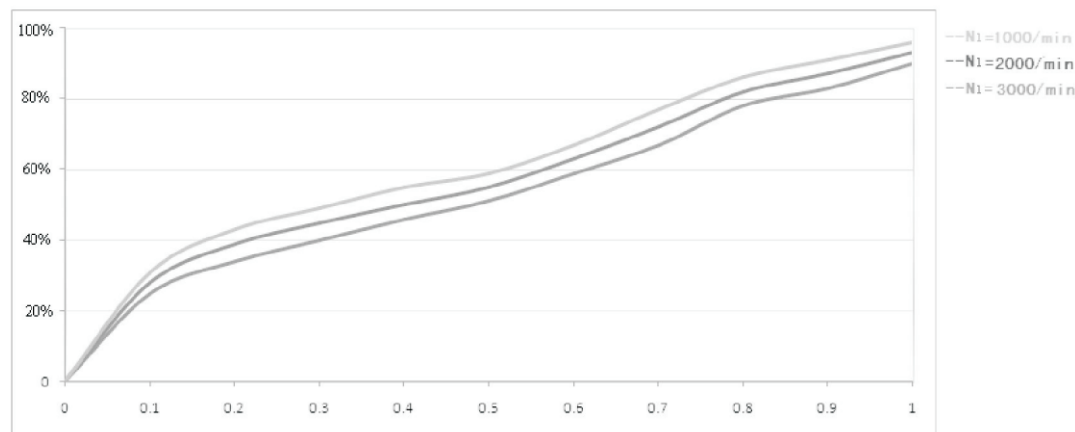

Hysteresis curve: Delay detection is to reverse the reducer stiffness. Get the hysteresis curve by testing. When detecting, the reducer input end is fixed, and then in the two rotation direction output were continuously loaded into the T2B maximum acceleration torque, and then gradually unloading, instrument record the moment imitation difference angle, the curve is a closed curve, from which we can calculate the backlash reducer (j) and torsional stiffness (Ct21).

$$C_{t21} = \frac{\Delta T}{\Delta \varphi}$$

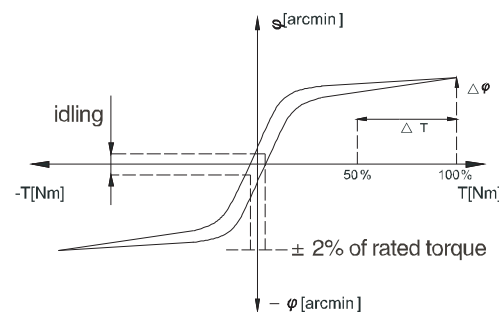

Return gap JT [Arcmin]: The maximum deviation of the output shaft of the speed reducer and the input angle. When measuring the gear input end is fixed, and then use the torque meter load certain torque at the output (2%T2B), to overcome the friction force in the speed reducer

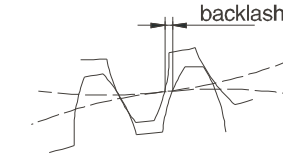

Arc [Arcmin]: Once divided into 60 minutes of arc (=60 Arcmin=60'). If the return gap standard is 1 Arcmin, meaning that the gear box to a circle, angular deviation of output is 1/60 °. In practical application, the angle deviation and shaft diameter of b=2 π R · a ° /360 °. That is to say, the output end of radius 500mm, gear accuracy of jt=3', deviation reducer turn to b=0.44mm.

Moment of inertia J[Kgcm2]: Represents an object to try to keep their rotational state (or stationary or rotating) a value characteristic. Value refers to the input.

Inertia ratio λ: Refers to the load inertia and inertia (motor drive system and the ratio between the speed reducer). This ratio determines the controllability of the system. The lambda value is greater, the moment of inertia is larger difference, high dynamic movement process more difficult to control, suggestions as far as possible the lambda value control in < 5. Reducer can reduce 1/2 load inertia.

The noise of [dB]: The selection of low noise reducer complete sets of equipment, contribute to environmental protection and health protection. The speed ratio and speed directly affects the noise level, is generally the higher the speed, more noise; noise ratio is smaller. In the sample value is the input speed is 3000rpm/min, with no load, measured from the reducer by one meter distance.

The average life of [h]: The speed reducer under the rated load, the rated input speed work in non continuous time.

The axial force Fa[N]: Refers to a force parallel to the axis of the. It is parallel to the output shaft. Action point and its output shaft axial deviation of a (Y2), will form a bending moment extra. The axial force of more than shown in the sample of the rated value, must use the coupling to counteract the bending force. [such as]

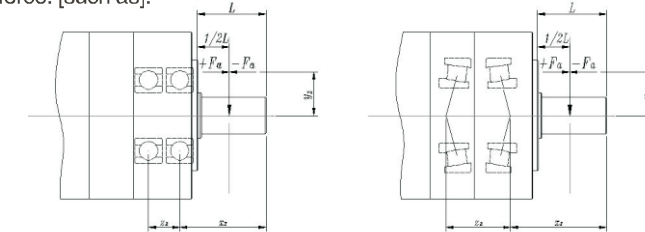

Radial force of Fr [N]: The effect of a vertical force on the axial force. Action point it with the shaft end with axial distance of (x2), this point as a leverage point. A bending moment form a lateral force.

The safety factor S: The safety coefficient is equal to the ratio of the reducer of the rated power input and power of motor.

The use of coefficient fs: Application characteristics using the coefficient of performance of speed reducer, it takes into account the load type and the daily working time of speed reducer. (detailed data type description)

Clamping hub: Add the hub for connecting the motor and reducer input end. If the motor shaft diameter is smaller than the inner diameter of the clamping hub, with a shaft sleeve. In order to ensure the high input speed combined with the surface and zero backlash concentricity of the transfer. The mechanism of improvement in our next, in order to achieve the dynamic balance can meet need not check any installation requirements.

Axle sleeve: The motor shaft diameter is smaller than the reducer clamping hub, and a sleeve to offset the diameter difference.

In accordance with the standard speed reducer:

Standard working temperature °C	-25 ~ +90
Special working temperature °C	-40 ~ +120
Levels of protection	IP 65
lubricating	Effective lubrication
Installation	Arbitrarily
Flange standard	D in 42 955 -N
Gear standards	JB 1 799 -76

Reducer selection

The selection of reducer should be considered the type of structure, the installation form, bearing working conditions, output speed, etc.

To determine the sample size: the carrying capacity of reducer is in the rated speed, working less than 12 hours per day, every hour starting number less than 10, it is smooth and shock free conditions.

If there is different usage should be selected according to the following steps..

(一) Check of the selected configuration:

a) according to the type of load, per hour and used to determine the coefficients of FS stop times and expected service life

The coefficient (fs)						
oadtype	Starting times per hour Z	The daily running time (h)				
		h<4	4<h<8	8<h<12	12<h<16	16<h<24
uniform load	Z<10	0.85	0.95	1.00	1.20	1.60
	10<Z<30	0.90	1.10	1.15	1.40	1.80
	30<Z<100	1.00	1.20	1.30	1.60	2.00
Secondary load	Z<10	1.00	1.20	1.30	1.60	2.00
	10<Z<30	1.10	1.35	1.45	1.80	2.20
	30<Z<100	1.20	1.45	1.60	2.00	2.40
heavy load	Z<10	1.20	1.45	1.60	2.00	2.40
	10<Z<30	1.30	1.55	1.75	2.20	2.60
	30<Z<100	1.40	1.65	1.90	2.40	2.80

1. On the basis of the required torque T_s , calculated the torque according to the following formula:

$$T_c = T_s * f_s$$

2. The transmission ratio of the required output speed N_2 and the input speed n_1 :

$$i = n_1 / n_2$$

3. To determine the T_c and I , according to the rated value table, select the most close to the calculation value of transmission ratio and gear units that meet the following conditions:

$$T_N \geq T_c$$

4. The safety factor [S]

Safety coefficient can press the table to choose

operating requirement	The minimum safety factor (S_{min})
High reliability	1.50~1.60
High reliability	1.25~1.30
General reliability	1.00~1.10

(二) check

After completion of the selection of the reducer, the following method can be used to check:

1. maximum torque

Confirm the instantaneous peak load torque and load rated maximum torque T_{max} starting torque can not exceed the speed reducer.

The specific values of parameters in the reducer ratings are listed in the table.

2. Cantilever load

Aim at the gear rack, cantilever synchronous belt wheel to bear large radial or axial force, when make a choice, according to a certain speed and force on the shaft extension $\frac{1}{2}$, the value of radial or axial force that you need must be less than the standard value of the sample book's (note speed value. The lower the speed, the radial force bearing is high. Stress points farther away from the shoulder, the radial bearing capacity will decline). If special circumstances, and our engineering staff.

3. If need to extend the working life, choose life coefficient (f_L) in the following table

working life	5000h	10000h	20000h	25000h	50000h	100000h
f_L	0.66	0.81	1.00	1.32	1.62	2.00

4. Radial load

For the role in the load axis point, need to be checked by the following formula:

$$F_r \geq F_{rj} * f_L$$

The F_r is the rated radial load output shaft center, the F_{rj} refers to the calculation of the output shaft with radial force

If the cantilever load is not in the axial midpoint, determine whether the offset distance X , our engineers will according to the specific conditions, the calculation of rated load, for the output speed and the working life is different, need to consider the velocity coefficient:

n_2	10	25	50	100	150	250	500	1000
f_{n2}	2.00	1.51	1.23	1.00	0.88	0.76	0.62	0.50

Working life coefficient (f_L) in the table, must meet the following conditions:

$$F_r * f_{n2} \geq F_{rj} * f_L$$

5. Thrust load

Count the size and direction of axial load F_a on an axis. To select the most appropriate according to the speed reducer output type and axial direction and the adjustment coefficient K_a . The axial force direction express of (+) and (-), have illustrated glossary.

$$F_a \geq F_{aj} * K_a$$

The F_a is the rated output shaft axial load, the F_{aj} refers to the calculation of the output shaft with axial force

Detected by the application of load axial characteristics determine the load factor in the K_a table:

K_a	load characteristic		
	uniform load	Secondary load	heavy load
	1.0	1.25	1.5

If there is the axial force and radial force at the same time, please contact with technical department.

PLE060 precision planetary reducer

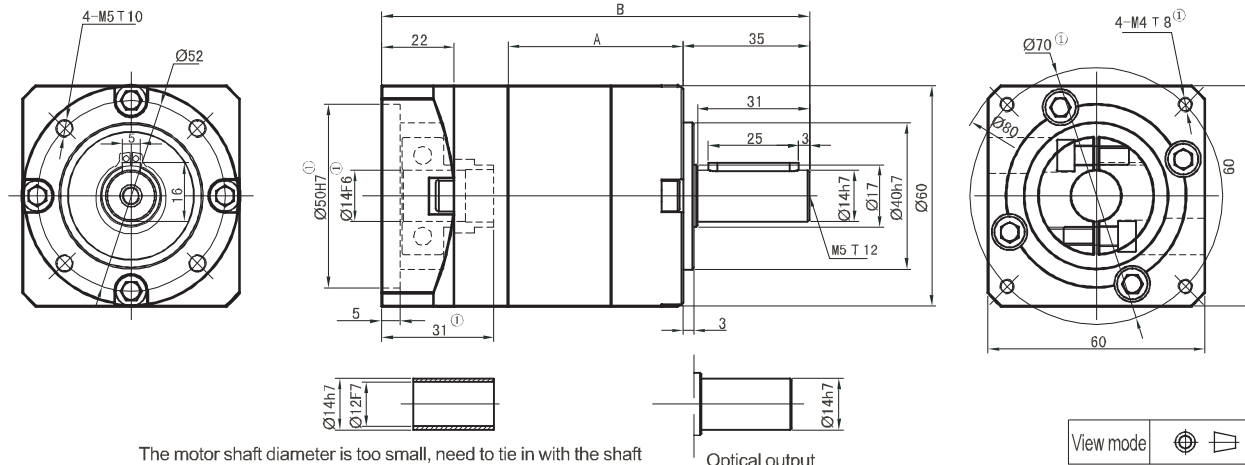

The motor shaft diameter is too small, need to tie in with the shaft sleeve installation, shaft sleeve minimum wall thickness of 1mm

Optical output

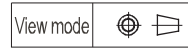

Stage	Stage 1 (Contains the speed ratio 3 4 5 7 10)		Stage 2 (Contains the speed ratio 12 16 20 25 28 35 40 50 70 100)				Stage 3 (Contains the speed ratio 80 100 125 140 175 200 250 350 400 500 700 1000)			
	A	B	A	B	A	B	A	B		
Length(mm)	46.5	118.5	63.0	135.0	79.5	151.5				
Rated input speed(rpm)	4000		4000				4000			
Maximum input speed(rpm)	8000		8000				8000			
The maximum radial force(N) ^②	485		605				670			
The maximum axial force(N) ^②	380		490				550			
No load torque(Nm)	About 0.6		About 0.3				About 0.3			
Efficiency with full load(%)	96		94				90			
Back lash(arcmin)	Precision: <3	Standard: <8	Precision: <5	Standard: <10	Precision: <8	Standard: <12				
Noise(dB)	≤58		≤58				≤58			
Weight(Kg)	1.0		1.3				1.6			
Average lifetime(h)	>20000									
Torsional rigidity(Nm/arcmin)	2.3									
lubricant	Effective lubrication									
direction of rotation	The input and output to the same									
Protection level	IP65									
Installation	arbitrarily									

Ratio(i)	3 ^②	4	5	7	10	12 ^②	16	20	25	28	35	40	50	70
Rated output torque(Nm)	16.5	27.0	29.5	19.5	8.5	30.0	30.0	30.0	33.0	30.0	33.0	30.0	33.0	21.5
maximum output torque(Nm)	33.0	54.0	59.0	39.0	17.0	60.0	60.0	60.0	66.0	60.0	66.0	60.0	66.0	43.0
Moment of inertia(Kgcm ²)	0.107	0.094	0.092	0.091	0.091	0.107	0.094	0.092	0.092	0.091	0.091	0.091	0.091	0.091

Ratio(i)	80	100 ^②	100 ^③	125	140	175	200	250	280	350	400	500	700	1000
Rated output torque(Nm)	37.5	9.5	37.5	41.0	37.5	41.0	37.5	41.0	37.5	41.0	37.5	41.0	27.0	11.5
maximum output torque(Nm)	75.0	19.0	75.0	82.0	75.0	82.0	75.0	82.0	75.0	82.0	75.0	82.0	54.0	23.0
Moment of inertia(Kgcm ²)	0.092	0.091	0.092	0.092	0.091	0.091	0.091	0.091	0.091	0.091	0.091	0.091	0.091	0.091

Subscript 1. Motor is different, matching size will vary, the adapter will be different. Our reducer can be matched to fix with any motor.
 Subscript 2. Acting on the output shaft center (1/2 axis strengths), permitted radial force and axial force (be forced at the same time), when the output speed of 1-Stage reducer is 100rpm, or 2-stage's output speed is 50rpm, or 3-stage's output speed is 10rpm.

PLF060 precision planetary reducer

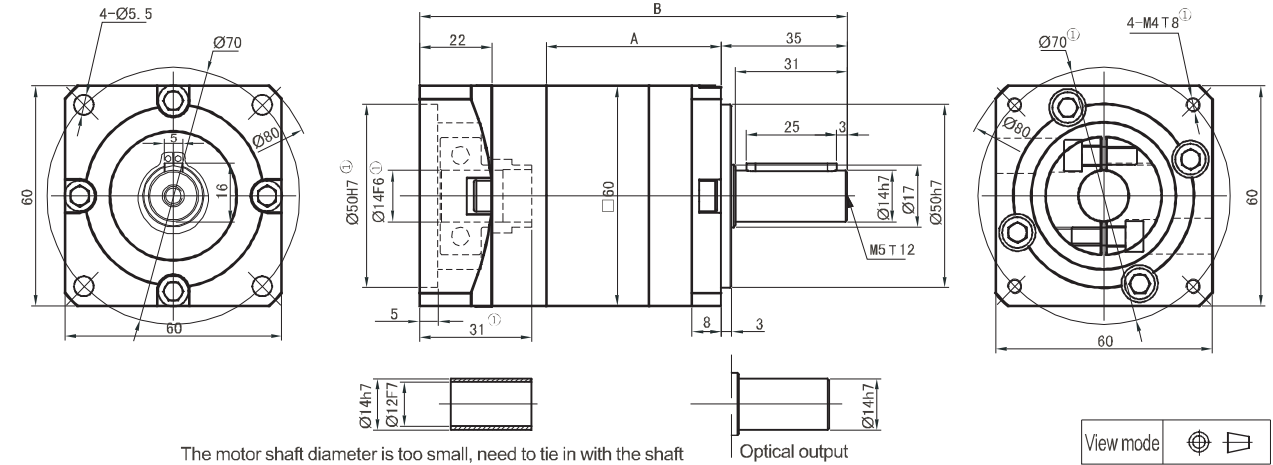

The motor shaft diameter is too small, need to tie in with the shaft sleeve installation, shaft sleeve minimum wall thickness of 1mm

Optical output



Stage	Stage 1 (Contains the speed ratio 3 4 5 7 10)		Stage 2 (Contains the speed ratio 12 16 20 25 28 35 40 50 70 100)				Stage 3 (Contains the speed ratio 80 100 125 140 175 200 250 350 400 500 700 1000)			
	A	B	A	B	A	B	A	B		
Length(mm)	46.5	118.5	63.0	135.0	79.5	151.5				
Rated input speed(rpm)	4000		4000				4000			
Maximum input speed(rpm)	8000		8000				8000			
The maximum radial force(N) ^②	485		605				670			
The maximum axial force(N) ^②	380		490				550			
No load torque(Nm)	About 0.6		About 0.3				About 0.3			
Efficiency with full load(%)	96		94				90			
Back lash(arcmin)	Precision: <3	Standard: <8	Precision: <5	Standard: <10	Precision: <8	Standard: <12				
Noise(dB)	≤58		≤58				≤58			
Weight(Kg)	1.0		1.3				1.6			
Average lifetime(h)	>20000									
Torsional rigidity(Nm/arcmin)	2.3									
lubricant	Effective lubrication									
direction of rotation	The input and output to the same									
Protection level	IP65									
Installation	arbitrarily									

Ratio(i)	3 ^②	4	5	7	10	12 ^②	16	20	25	28	35	40	50	70
Rated output torque(Nm)	16.5	27.0	29.5	19.5	8.5	30.0	30.0	30.0	33.0	30.0	33.0	30.0	33.0	21.5
maximum output torque(Nm)	33.0	54.0	59.0	39.0	17.0	60.0	60.0	60.0	66.0	60.0	66.0	60.0	66.0	43.0
Moment of inertia(Kgcm ²)	0.107	0.094	0.092	0.091	0.091	0.107	0.094	0.092	0.092	0.091	0.091	0.091	0.091	0.091

Ratio(i)	80	100 ^②	100 ^③	125	140	175	200	250	280	350	400	500	700	1000
Rated output torque(Nm)	37.5	9.5	37.5	41.0	37.5	41.0	37.5	41.0	37.5	41.0	37.5	41.0	27.0	11.5
maximum output torque(Nm)	75.0	19.0	75.0	82.0	75.0	82.0	75.0	82.0	75.0	82.0	75.0	82.0	54.0	23.0
Moment of inertia(Kgcm ²)	0.092	0.091	0.092	0.092	0.091	0.091	0.091	0.091	0.091	0.091	0.091	0.091	0.091	0.091

Subscript 1. Motor is different, matching size will vary, the adapter will be different. Our reducer can be matched to fix with any motor.
 Subscript 2. Acting on the output shaft center (1/2 axis strengths), permitted radial force and axial force (be forced at the same time), when the output speed of 1-Stage reducer is 100rpm, or 2-stage's output speed is 50rpm, or 3-stage's output speed is 10rpm.

PLS060 precision planetary reducer

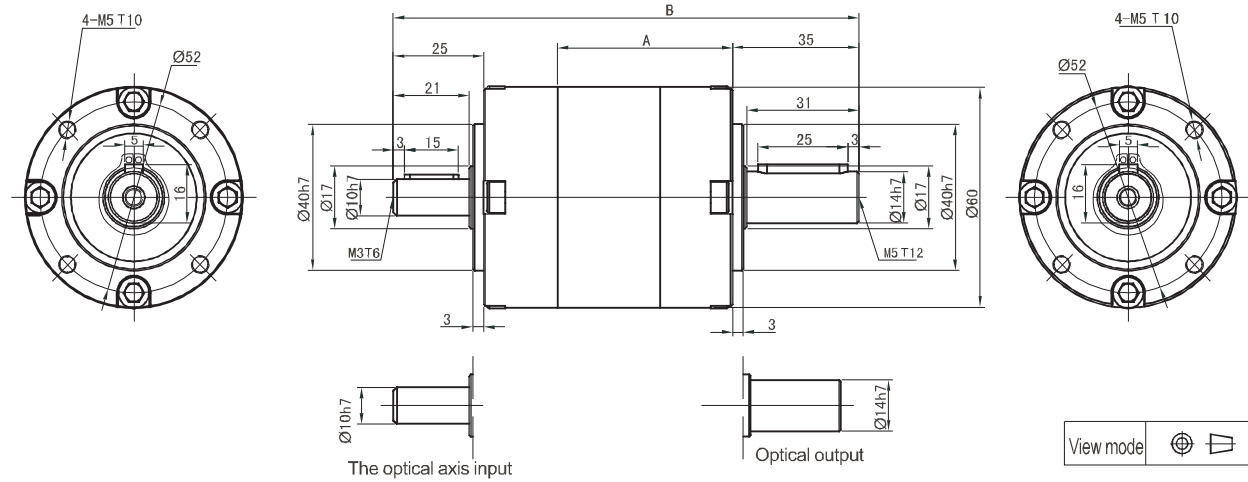

Stage	Stage 1 (Contains the speed ratio 3 4 5 7 10)		Stage 2 (Contains the speed ratio 12 16 20 25 28 35 40 50 70 100)				Stage 3 (Contains the speed ratio 80 100 125 140 175 200 250 300 400 500 700 1000)			
	A	B	A	B	A	B	A	B	C	
Length(mm)	46.5	129.0	63.0	140.5	79.5	162				
Rated input speed(rpm)	4000		4000				4000			
Maximum input speed(rpm)	8000		8000				8000			
The maximum radial force(N) ^②			170							
The maximum axial force(N) ^②			100							
No load torque(Nm)	About 0.6		About 0.3				About 0.3			
Efficiency withfull load(%)	96		94				90			
Back lash(arcmin)	Precision: <3	Standard: <8	Precision: <5	Standard: <10	Precision: <8	Standard: <12				
Noise(dB)	≤58		≤58				≤58			
Weight(Kg)	1.0		1.3				1.6			
Average lifetime(h)	>20000									
Torsional rigidity(Nm/arcmin)	2.3									
lubricant	Effective lubrication									
direction of rotation	The input and output to the same									
Protection level	IP65									
Installation	arbitrarily									

Ratio(i)	3 ^①	4	5	7	10	12 ^①	16	20	25	28	35	40	50	70
Rated output torque(Nm)	16.5	27.0	29.5	19.5	8.5	30.0	30.0	30.0	33.0	30.0	33.0	30.0	33.0	21.5
maximum output torque(Nm)	33.0	54.0	59.0	39.0	17.0	60.0	60.0	60.0	66.0	60.0	66.0	60.0	66.0	43.0
Moment of inertia(Kgcm ²)	0.037	0.025	0.023	0.021	0.02	0.037	0.025	0.023	0.023	0.021	0.021	0.02	0.02	0.02

Ratio(i)	80	100 ^{Stage 2}	100 ^{Stage 3}	125	140	175	200	250	280	350	400	500	700	1000
Rated output torque(Nm)	37.5	9.5	37.5	41.0	37.5	41.0	37.5	41.0	37.5	41.0	37.5	41.0	27.0	11.5
maximum output torque(Nm)	75.0	19.0	75.0	82.0	75.0	82.0	75.0	82.0	75.0	82.0	75.0	82.0	54.0	23.0
Moment of inertia(Kgcm ²)	0.023	0.02	0.023	0.023	0.021	0.021	0.02	0.02	0.02	0.02	0.02	0.02	0.02	0.02

Subscript 1. In the input speed is 2000rpm, is applied to the input shaft center (1/2 axis strengths) the measured radial force and axial force (allowable stress at the same time). The output force with PLE060.

ZPLE060 precision planetary reducer

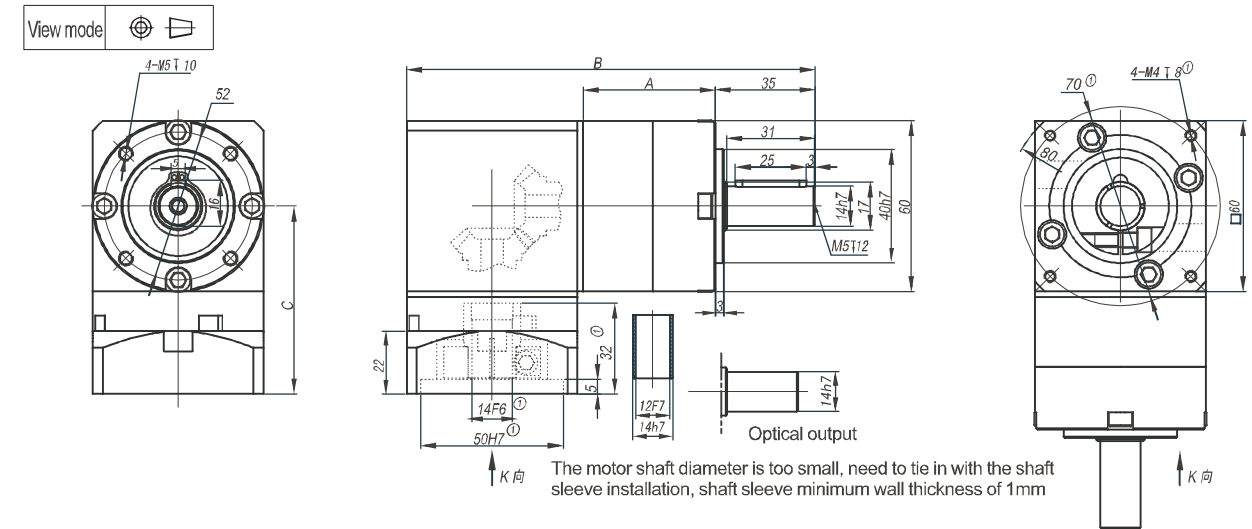

Stage	Stage 1 (Contains the speed ratio 3 4 5 7 10)			Stage 2 (Contains the speed ratio 12 16 20 25 28 35 40 50 70 100)			Stage 3 (Contains the speed ratio 80 100 125 140 175 200 250 300 400 500 700 1000)		
	A	B	C	A	B	C	A	B	C
Length(mm)	46.5	143.5	66.0	63.0	160.0	66.0	79.5	176.5	66.0
No load torque(Nm)	About 0.6			About 0.3			About 0.3		
Efficiency withfull load(%)	95			93			90		
Back lash(arcmin)	Precision: <4	Standard: <10		Precision: <6	Standard: <13		Precision: <8	Standard: <16	
Noise(dB)	≤58			≤58			≤58		
Weight(Kg)	2.2			2.5			2.8		
direction of rotation	Input and output in different directions								
Not listed parameters refer to the PLE060 (including the maximum radial force rated input speed, the maximum input speed \ maximum axial force, the average life expectancy, torsional rigidity, lubricating oil, protection grade, installation, reduction ratio, rated output torque, maximum output torque, moment of inertia)									

Subscript 1. Motor without, with matching size will vary, the adapter will be different. The company can be arranged to match with any motor speed reducer.

ZPLF060 precision planetary reducer

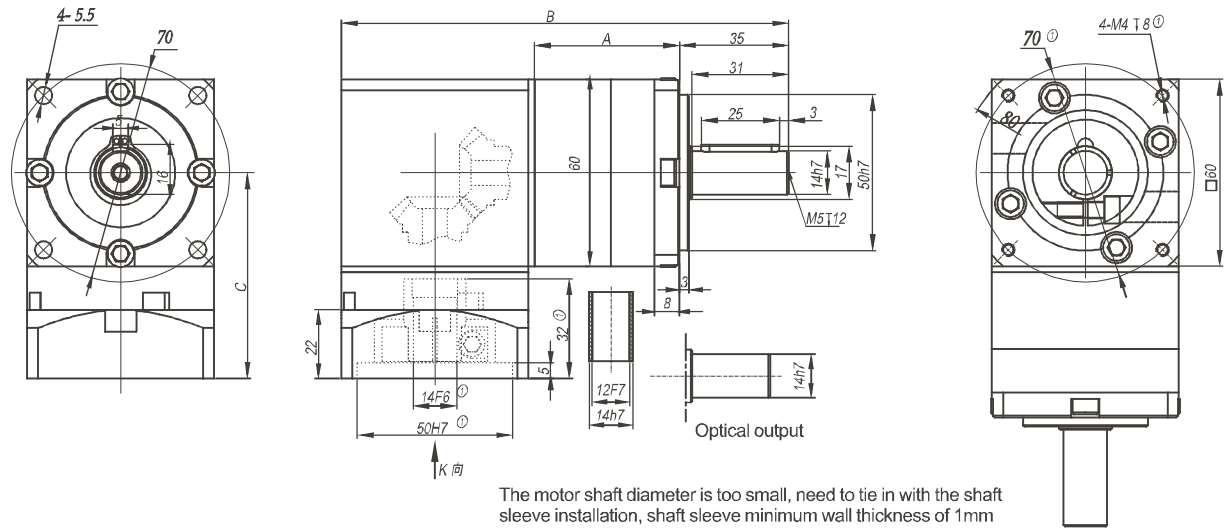

The motor shaft diameter is too small, need to tie in with the shaft sleeve installation, shaft sleeve minimum wall thickness of 1mm

Stage	Stage 1 (Contains the speed ratio 7 10)			Stage 2 (Contains the speed ratio 20 25 35 40 50 70 100)			Stage 3 (80 100 125 140 175 200 250 300 400 500 1000) speed ratio		
	A	B	C	A	B	C	A	B	C
Length(mm)	46.5	143.5	66.0	63.0	160.0	66.0	79.5	176.5	66.0
No load torque(Nm)	About 0.6			About 0.3			About 0.3		
Efficiency with full load(%)	95			93			90		
Back lash(arcmin)	Precision: <4	Standard: <10		Precision: <6	Standard: <13		Precision: <8	Standard: <16	
Noise(dB)	≤58			≤58			≤58		
Weight(Kg)	2.2			2.5			2.8		
direction of rotation	Input and output in different directions								

Not listed parameters refer to the PLE060 (including the maximum radial force rated input speed, the maximum input speed \ maximum axial force, the average life expectancy, torsional rigidity, lubricating oil, protection grade, installation, reduction ratio, rated output torque, maximum output torque, moment of inertia)

Subscript 1. Motor without, with matching size will vary, the adapter will be different. The company can be arranged to match with any motor speed reducer.

PLH060 precision planetary reducer

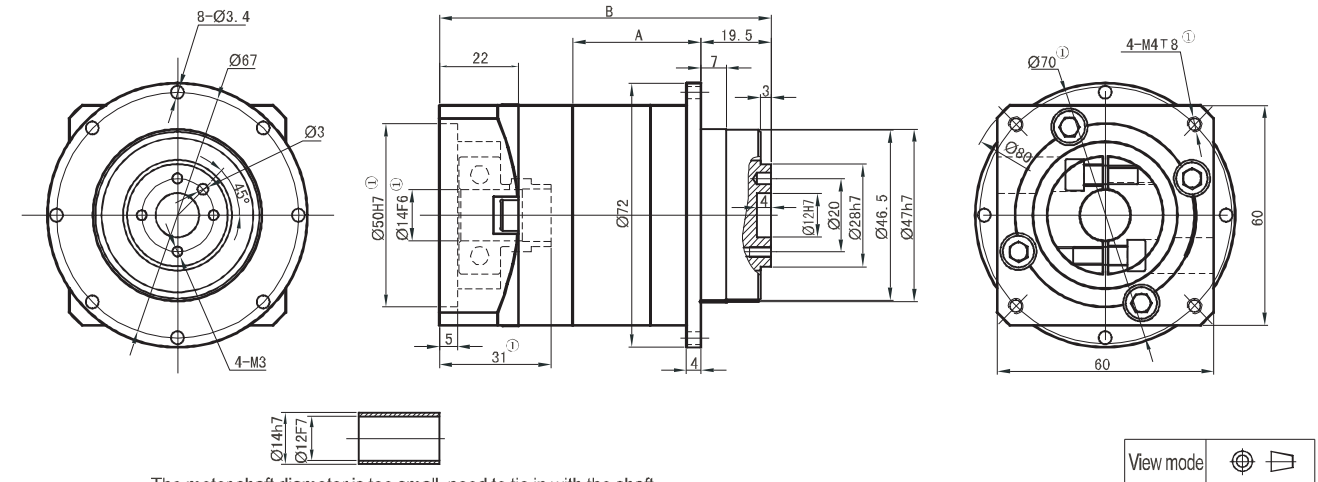

The motor shaft diameter is too small, need to tie in with the shaft sleeve installation, shaft sleeve minimum wall thickness of 1mm

Stage	Stage 1 (Contains the speed ratio 7 10)		Stage 2 (Contains the speed ratio 20 25 35 40 50 70 100)		Stage 3 (80 100 125 140 175 200 250 300 400 500 1000) speed ratio	
	A	B	A	B	A	B
Length(mm)	35.5	92.0	52.0	108.5	68.5	125.0
Rated input speed(rpm)	4000		4000		4000	
Maximum input speed(rpm)	8000		8000		8000	
The maximum radial force(N) ^②	300		400		760	
The maximum axial force(N) ^②	280		380		600	
No load torque(Nm)	About 0.6		About 0.3		About 0.3	
Efficiency with full load(%)	96		94		90	
Back lash(arcmin)	Precision: <3	Standard: <8	Precision: <5	Standard: <10	Precision: <8	Standard: <12
Noise(dB)	≤58		≤58		≤58	
Weight(Kg)	1.1		1.4		1.7	
Average lifetime(h)	>20000					
Torsional rigidity(Nm/arcmin)	1.6					
lubricant	Effective lubrication					
direction of rotation	The input and output to the same					
Protection level	IP65					
Installation	arbitrarily					

Ratio (i)	3 ^①	4	5	7	10	12 ^②	16	20	25	28	35	40	50	70
Rated output torque(Nm)	16.5	27.0	29.5	19.5	8.5	30.0	30.0	30.0	33.0	30.0	33.0	30.0	33.0	21.5
maximum output torque(Nm)	54.0	59.0	39.0	17.0	60.0	60.0	60.0	66.0	60.0	66.0	60.0	66.0	66.0	43.0
Moment of inertia(Kgcm ²)	0.07	0.094	0.092	0.091	0.091	0.107	0.094	0.092	0.092	0.091	0.091	0.091	0.091	0.091

Ratio (i)	80	100 ^①	100 ^②	125	140	175	200	250	280	350	400	500	700	1000
Rated output torque(Nm)	17.5	9.5	37.5	41.0	37.5	41.0	37.5	41.0	37.5	41.0	37.5	41.0	27.0	11.5
maximum output torque(Nm)	75.0	19.0	75.0	82.0	75.0	82.0	75.0	82.0	75.0	82.0	75.0	82.0	54.0	23.0
Moment of inertia(Kgcm ²)	0.092	0.091	0.092	0.092	0.091	0.091	0.091	0.091	0.091	0.091	0.091	0.091	0.091	0.091

Subscript 1. Motor without, with matching size will vary, the adapter will be different. The company can be arranged to match with any motor speed reducer.
 Subscript 2. Single stage in the output when the rotate speed is 100rpm, double the output speed is 50rpm, three grade in the output when the rotate speed is 10rpm, acting on the output shaft center (1/2 axis strengths) the not allow radial force and axial force (force at the same time).

PLE090 precision planetary reducer

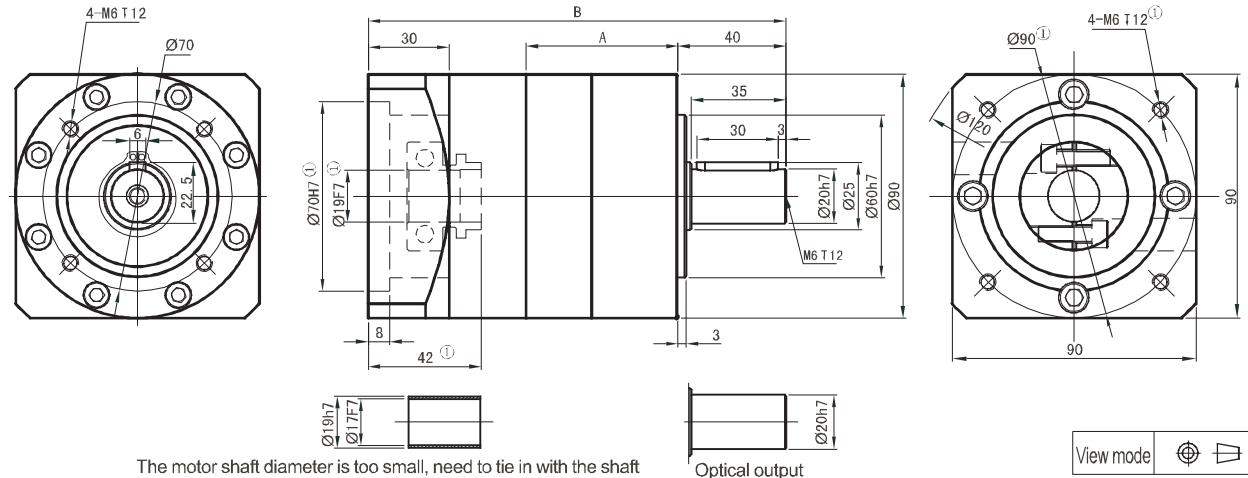

The motor shaft diameter is too small, need to tie in with the shaft sleeve installation, shaft sleeve minimum wall thickness of 1mm

Optical output



Stage	Stage 1 (Contains the speed ratio 3 4 5 7 10)		Stage 2 (Contains the speed ratio 12 16 20 25 28 35 40 50 70 100)		Stage 3 (Contains the speed ratio 80 100 125 140 175 200 250 350 400 500 700 1000)	
	A	B	A	B	A	B
Length(mm)	56.0	154.5	80.0	178.5	104.0	202.5
Rated input speed(rpm)	3500		3500		3500	
Maximum input speed(rpm)	6000		6000		6000	
The maximum radial force(N) ^②	1020		1270		1420	
The maximum axial force(N) ^②	850		1100		1250	
No load torque(Nm)	About 0.8		About 0.4		About 0.4	
Efficiency withfull load(%)	96		94		90	
Back lash(arcmin)	Precision: <3	Standard: <8	Precision: <5	Standard: <10	Precision: <8	Standard: <12
Noise(dB)	≤62		≤62		≤62	
Weight(Kg)	2.8		3.4		4.0	
Average lifetime(h)	>20000					
Torsional rigidity(Nm/arcmin)	7.5					
lubricant	Effective lubrication					
direction of rotation	The input and output to the same					
Protection level	IP65					
Installation	arbitrarily					

Ratio(i)	3 ^(②)	4	5	7	10	12 ^(②)	16	20	25	28	35	40	50	70
Rated output torque(Nm)	60.0	86.0	94.5	64.0	39.5	96.0	96.0	96.0	105.5	96.0	105.5	96.0	105.5	71.5
maximum output torque(Nm)	120.0	172.0	189.0	128.0	79.0	192.0	192.0	192.0	211.0	192.0	211.0	192.0	211.0	143.0
Moment of inertia(Kgcm ²)	0.4	0.309	0.291	0.285	0.283	0.4	0.309	0.291	0.291	0.285	0.285	0.283	0.283	0.283

Ratio(i)	80	100 ^(Stage 2)	100 ^(Stage 3)	125	140	175	200	250	280	350	400	500	700	1000
Rated output torque(Nm)	120.0	44.0	120.0	132.0	120.0	132.0	120.0	132.0	120.0	132.0	44.0	132.0	89.5	55.0
maximum output torque(Nm)	240.0	88.0	240.0	264.0	240.0	264.0	240.0	264.0	240.0	264.0	88.0	264.0	179.0	110.0
Moment of inertia(Kgcm ²)	0.291	0.283	0.291	0.291	0.285	0.285	0.283	0.283	0.283	0.283	0.283	0.283	0.283	0.283

Subscript 1. Motor is different, matching size will vary, the adapter will be different. Our reducer can be matched to fix with any motor.
 Subscript 2. Acting on the output shaft center (1/2 axis strengths), permitted radial force and axial force (be forced at the same time), when the output speed of 1-Stage reducer is 100rpm, or 2-stage's output speed is 50rpm, or 3-stage's output speed is 10rpm.

PLF090 precision planetary reducer

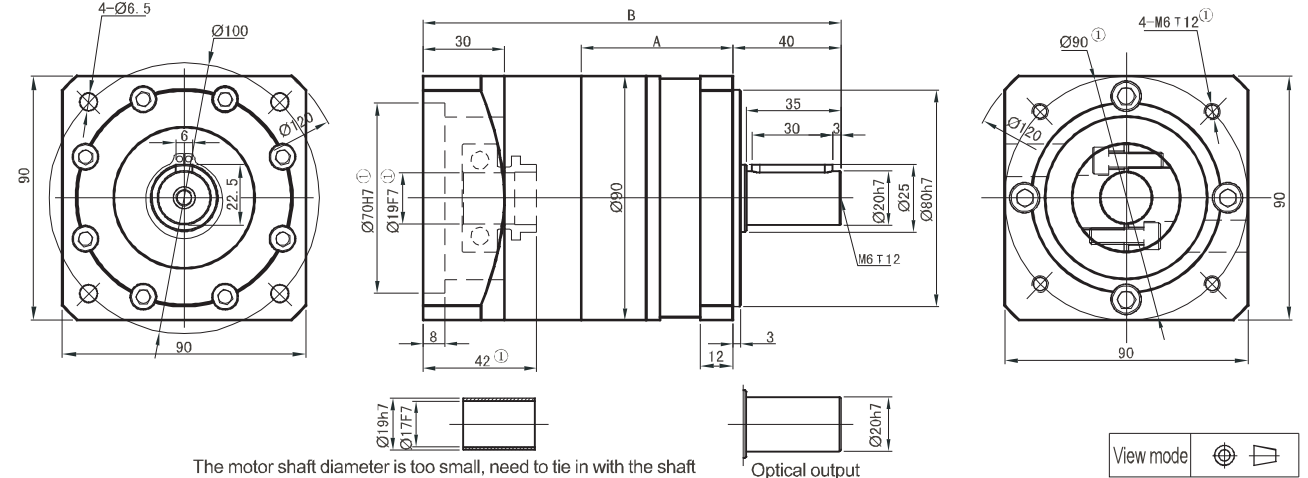

The motor shaft diameter is too small, need to tie in with the shaft sleeve installation, shaft sleeve minimum wall thickness of 1mm

Optical output

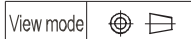

Stage	Stage 1 (Contains the speed ratio 3 4 5 7 10)		Stage 2 (Contains the speed ratio 12 16 20 25 28 35 40 50 70 100)		Stage 3 (Contains the speed ratio 80 100 125 140 175 200 250 350 400 500 700 1000)	
	A	B	A	B	A	B
Length(mm)	56.0	154.5	80.0	178.5	104.0	202.5
Rated input speed(rpm)	3500		3500		3500	
Maximum input speed(rpm)	6000		6000		6000	
The maximum radial force(N) ^②	1020		1270		1420	
The maximum axial force(N) ^②	850		1100		1250	
No load torque(Nm)	About 0.8		About 0.4		About 0.4	
Efficiency withfull load(%)	96		94		90	
Back lash(arcmin)	Precision: <3	Standard: <8	Precision: <5	Standard: <10	Precision: <8	Standard: <12
Noise(dB)	≤62		≤62		≤62	
Weight(Kg)	2.8		3.4		4.0	
Average lifetime(h)	>20000					
Torsional rigidity(Nm/arcmin)	7.5					
lubricant	Effective lubrication					
direction of rotation	The input and output to the same					
Protection level	IP65					
Installation	arbitrarily					

Ratio(i)	3 ^(②)	4	5	7	10	12 ^(②)	16	20	25	28	35	40	50	70
Rated output torque(Nm)	60.0	86.0	94.5	64.0	39.5	96.0	96.0	96.0	105.5	96.0	105.5	96.0	105.5	71.5
maximum output torque(Nm)	120.0	172.0	189.0	128.0	79.0	192.0	192.0	192.0	211.0	192.0	211.0	192.0	211.0	143.0
Moment of inertia(Kgcm ²)	0.4	0.309	0.291	0.285	0.283	0.4	0.309	0.291	0.291	0.285	0.285	0.283	0.283	0.283

Ratio(i)	80	100 ^(Stage 2)	100 ^(Stage 3)	125	140	175	200	250	280	350	400	500	700	1000
Rated output torque(Nm)	120.0	44.0	120.0	132.0	120.0	132.0	120.0	132.0	120.0	132.0	44.0	132.0	89.5	55.0
maximum output torque(Nm)	240.0	88.0	240.0	264.0	240.0	264.0	240.0	264.0	240.0	264.0	88.0	264.0	179.0	110.0
Moment of inertia(Kgcm ²)	0.291	0.283	0.291	0.291	0.285	0.285	0.283	0.283	0.283	0.283	0.283	0.283	0.283	0.283

Subscript 1. Motor is different, matching size will vary, the adapter will be different. Our reducer can be matched to fix with any motor.
 Subscript 2. Acting on the output shaft center (1/2 axis strengths), permitted radial force and axial force (be forced at the same time), when the output speed of 1-Stage reducer is 100rpm, or 2-stage's output speed is 50rpm, or 3-stage's output speed is 10rpm.

PLS090 precision planetary reducer

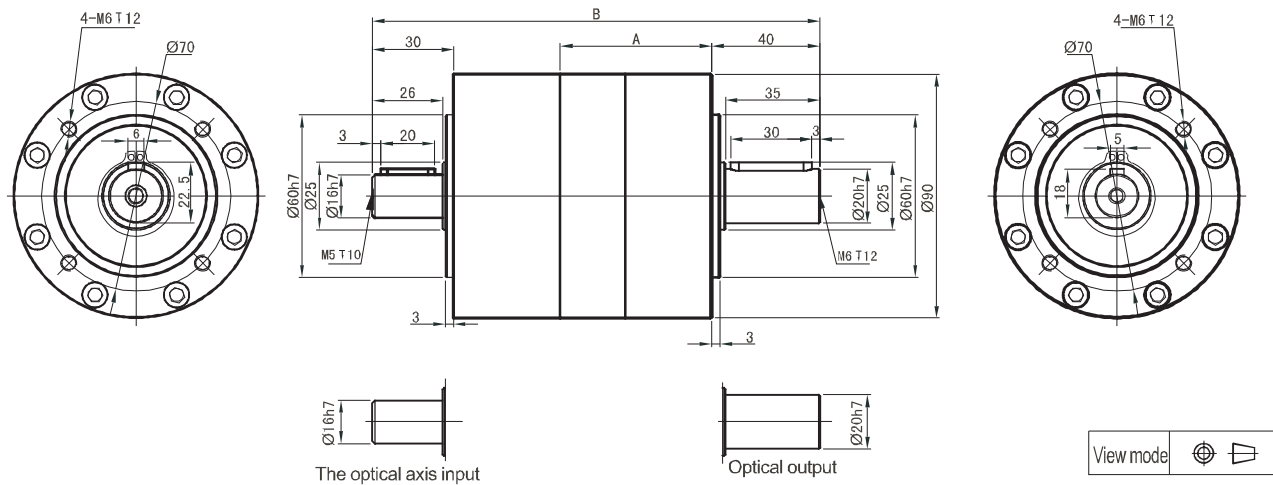

Stage	Stage 1 (Contains the speed ratio 3 4 5 7 10)		Stage 2 (Contains the speed ratio 12 16 20 25 28 35 40 50 70 100)		Stage 3 (Contains the speed ratio 80 100 125 140 175 200 250 350 400 500 700 1000)	
	A	B	A	B	A	B
Length(mm)	56.0	165.5	80.0	189.5	104.0	213.5
Rated input speed(rpm)	3500		3500		3500	
Maximum input speed(rpm)	6000		6000		6000	
The maximum radial force(N) ^②			415			
The maximum axial force(N) ^②			260			
No load torque(Nm)	About 0.8		About 0.4		About 0.4	
Efficiency with full load(%)	96		94		90	
Back lash(arcmin)	Precision: <3	Standard: <8	Precision: <5	Standard: <10	Precision: <8	Standard: <12
Noise(dB)	≤62		≤62		≤62	
Weight(Kg)						
Average lifetime(h)			>20000			
Torsional rigidity(Nm/arcmin)			7.5			
lubricant			Effective lubrication			
direction of rotation			The input and output to the same			
Protection level			IP65			
Installation			arbitrarily			

Ratio(i)	3 ^①	4	5	7	10	12 ^①	16	20	25	28	35	40	50	70
Rated output torque(Nm)	60.0	86.0	94.5	64.0	39.5	96.0	96.0	96.0	105.5	96.0	105.5	96.0	105.5	71.5
maximum output torque(Nm)	120.0	172.0	189.0	128.0	79.0	192.0	192.0	192.0	211.0	192.0	211.0	192.0	211.0	143.0
Moment of inertia(Kgcm ²)	0.281	0.189	0.173	0.167	0.163	0.281	0.189	0.173	0.173	0.167	0.167	0.163	0.163	0.163

Ratio(i)	80	100 ^②	100 ^②	125	140	175	200	250	280	350	400	500	700	1000
Rated output torque(Nm)	120.0	44.0	120.0	132.0	120.0	132.0	120.0	132.0	120.0	132.0	44.0	132.0	89.5	55.0
maximum output torque(Nm)	240.0	88.0	240.0	264.0	240.0	264.0	240.0	264.0	240.0	264.0	88.0	264.0	179.0	110.0
Moment of inertia(Kgcm ²)	0.173	0.163	0.173	0.173	0.167	0.167	0.163	0.163	0.163	0.163	0.163	0.163	0.163	0.163

Subscript 1. In the input speed is 2000rpm, is applied to the input shaft center (1/2 axis strengths) the measured radial force and axial force (allowable stress at the same time). The output force with PLE090.

ZPLE090 precision planetary reducer

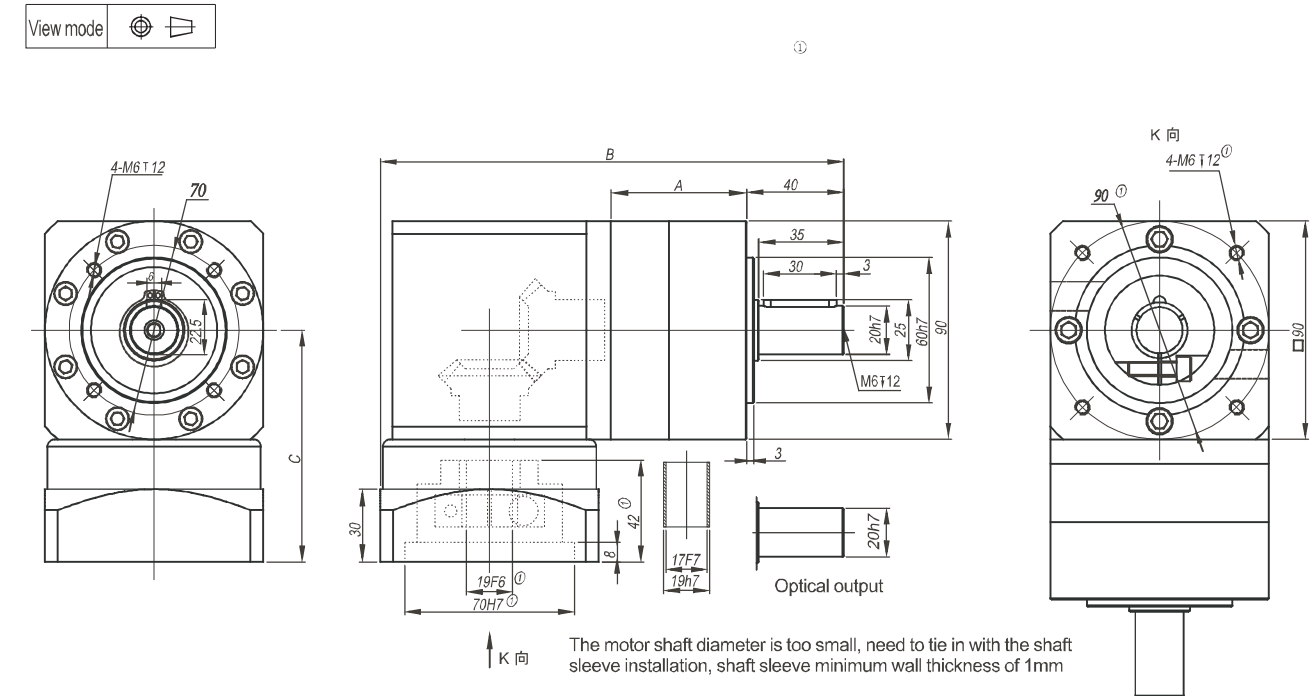

Stage	Stage 1 (Contains the speed ratio 3 4 5 7 10)			Stage 2 (Contains the speed ratio 12 16 20 25 28 35 40 50 70 100)			Stage 3 (Contains the speed ratio 80 100 125 140 175 200 250 350 400 500 700 1000)		
	A	B	C	A	B	C	A	B	C
Length(mm)	56.0	191.0	95.5	80.0	215.0	95.5	104.0	239.0	95.5
No load torque(Nm)	About 0.8			About 0.4			About 0.4		
Efficiency with full load(%)	95			93			90		
Back lash(arcmin)	Precision: <4	Standard: <10		Precision: <6	Standard: <13		Precision: <8	Standard: <16	
Noise(dB)	≤62			≤62			≤62		
Weight(Kg)	4.7			5.3			5.9		
direction of rotation				Input and output in different directions					

Not listed parameters refer to the PLE090 (including the maximum radial force rated input speed, the maximum input speed \ maximum axial force, the average life expectancy, torsional rigidity, lubricating oil, protection grade, installation, reduction ratio, rated output torque, maximum output torque, moment of inertia)

Subscript 1. Motor without, with matching size will vary, the adapter will be different. The company can be arranged to match with any motor speed reducer.

ZPLF090 precision planetary reducer

View mode

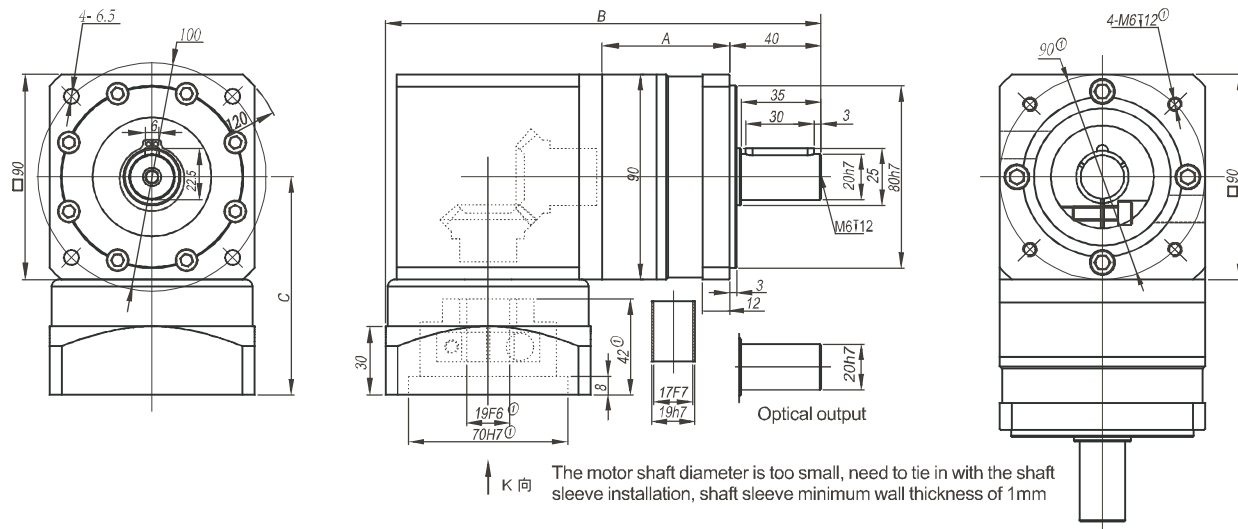

Stage	Stage 1 (Contains the speed ratio 3 4 5 7 10)			Stage 2 (Contains the speed ratio 12 16 20 25 28 35 40 50 70 100)			Stage 3 (Contains the speed ratio 80 100 125 140 175 200 250 350 400 500 700 1000)		
	A	B	C	A	B	C	A	B	C
Length(mm)	56.0	191.0	95.5	80.0	215.0	95.5	104.0	239.0	95.5
No load torque(Nm)	About 0.8			About 0.4			About 0.4		
Efficiency withfull load(%)	95			93			90		
Back lash(arcmin)	Precision: <4	Standard: <10		Precision: <6	Standard: <13		Precision: <8	Standard: <16	
Noise(dB)	≤62			≤62			≤62		
Weight(Kg)	4.7			5.3			5.9		
direction of rotation	Input and output in different directions								

Not listed parameters refer to the PLE090 (including the maximum radial force rated input speed, the maximum input speed \ maximum axial force, the average life expectancy, torsional rigidity, lubricating oil, protection grade, installation, reduction ratio, rated output torque, maximum output torque, moment of inertia)

Subscript 1. Motor without, with matching size will vary, the adapter will be different. The company can be arranged to match with any motor speed reducer.

PLH090 precision planetary reducer

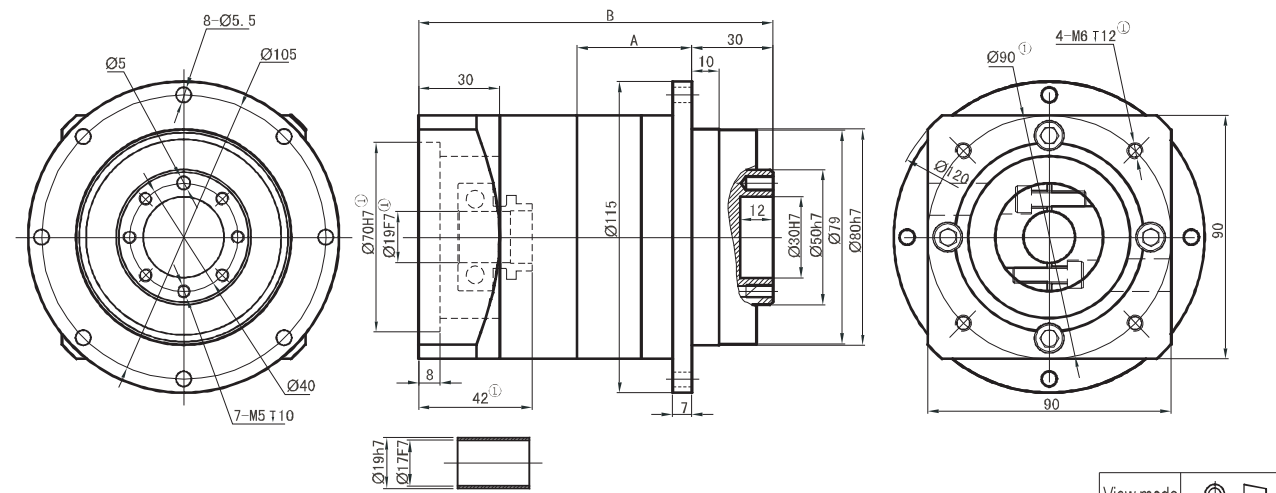

View mode

Stage	Stage 1 (Contains the speed ratio 3 4 5 7 10)				Stage 2 (Contains the speed ratio 12 16 20 25 28 35 40 50 70 100)				Stage 3 (Contains the speed ratio 80 100 125 140 175 200 250 350 400 500 700 1000)			
	A	B	A	B	A	B	A	B				
Length(mm)	42.5	131.0	66.5	155.0	90.5	179.0						
Rated input speed(rpm)	3500				3500				3500			
Maximum input speed(rpm)	6000				6000				6000			
The maximum radial force(N) ^②	1050				1450				2600			
The maximum axial force(N) ^②	800				1000				1900			
No load torque(Nm)	About 0.8				About 0.4				About 0.4			
Efficiency withfull load(%)	96				94				90			
Back lash(arcmin)	Precision: <3	Standard: <8			Precision: <5	Standard: <10			Precision: <8	Standard: <12		
Noise(dB)	≤62				≤62				≤62			
Weight(Kg)	3.5				4.1				4.7			
Average lifetime(h)	>20000											
Torsional rigidity(Nm/arcmin)	4.5											
lubricant	Effective lubrication											
direction of rotation	The input and output to the same											
Protection level	IP65											
Installation	arbitrarily											

Ratio(i)	3 ^①	4	5	7	10	12 ^①	16	20	25	28	35	40	50	70
Rated output torque(Nm)	60.0	86.0	94.5	64.0	39.5	96.0	96.0	96.0	105.5	96.0	105.5	96.0	105.5	71.5
maximum output torque(Nm)	120.0	172.0	189.0	128.0	79.0	192.0	192.0	192.0	211.0	192.0	211.0	192.0	211.0	143.0
Moment of inertial(Kgcm ²)	0.4	0.309	0.291	0.085	0.283	0.4	0.309	0.291	0.291	0.285	0.285	0.283	0.283	0.283

Ratio(i)	80	100	100 ^①	125	140	175	200	250	280	350	400	500	700	1000
Rated output torque(Nm)	120.0	44.0	120.0	132.0	120.0	132.0	120.0	132.0	120.0	132.0	44.0	132.0	89.5	55.0
maximum output torque(Nm)	240.0	88.0	240.0	264.0	240.0	264.0	240.0	264.0	240.0	264.0	88.0	264.0	179.0	110.0
Moment of inertial(Kgcm ²)	0.291	0.283	0.291	0.291	0.285	0.285	0.283	0.283	0.283	0.283	0.283	0.283	0.283	0.283

Subscript 1. Motor is different, matching size will vary, the adapter will be different. Our reducer can be matched to fix with any motor.
 Subscript 2. Acting on the output shaft center (1/2 axis strengths), permitted radial force and axial force (be forced at the same time), when the output speed of 1-Stage reducer is 100rpm, or 2-stage's output speed is 50rpm, or 3-stage's output speed is 10rpm.

PLE120 precision planetary reducer

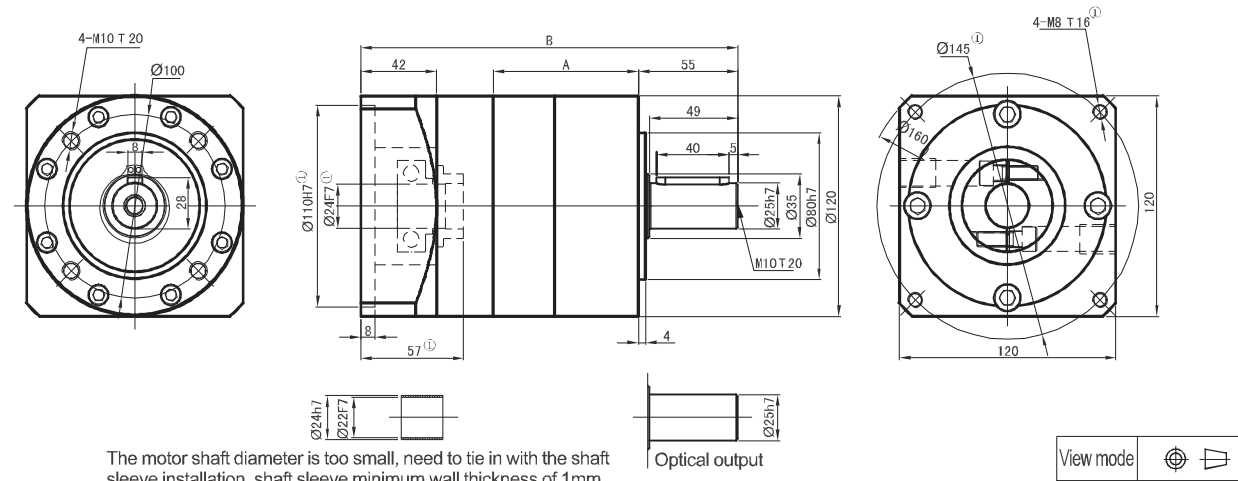

The motor shaft diameter is too small, need to tie in with the shaft sleeve installation, shaft sleeve minimum wall thickness of 1mm

Optical output

View mode

Stage	Stage 1 (Contains the speed ratio 3 4 5 7 10)		Stage 2 (Contains the speed ratio 12 16 20 25 28 35 40 50 70 100)				Stage 3 (Contains the speed ratio 80 100 125 140 175 200 250 350 400 500 700 1000)			
	A	B	A	B	A	B	A	B		
Length(mm)	80.5	209.0	112.0	240.5	143.5	272.0				
Rated input speed(rpm)	3000		3000				3000			
Maximum input speed(rpm)	4800		4800				4800			
The maximum radial force(N) ^②	2230		2840				3020			
The maximum axial force(N) ^②	1550		2100				2600			
No load torque(Nm)	About 1.3		About 0.6				About 0.6			
Efficiency with full load(%)	96		94				90			
Back lash(arcmin)	Precision: <3	Standard: <8	Precision: <5	Standard: <10	Precision: <8	Standard: <12				
Noise(dB)	≤65		≤65				≤65			
Weight(Kg)	6.8		8.8				11.0			
Average lifetime(h)	>20000									
Torsional rigidity(Nm/arcmin)	15.0									
lubricant	Effective lubrication									
direction of rotation	The input and output to the same									
Protection level	IP65									
Installation	arbitrarily									

Ratio(i)	3 ^①	4	5	7	10	12 ^①	16	20	25	28	35	40	50	70
Rated output torque(Nm)	148.0	222.0	235.0	158.0	93.0	250.0	250.0	250.0	264.0	250.0	264.0	250.0	264.0	177.0
maximum output torque(Nm)	296.0	444.0	470.0	316.0	186.0	500.0	500.0	500.0	528.0	500.0	528.0	500.0	528.0	354.0
Moment of inertia(Kgcm ²)	1.65	1.22	1.15	1.13	1.11	1.65	1.22	1.15	1.15	1.13	1.13	1.11	1.11	1.11

Ratio(i)	80	100 ^②	100 ^③	125	140	175	200	250	280	350	400	500	700	1000
Rated output torque(Nm)	310.0	104.0	310.0	329.0	310.0	329.0	310.0	329.0	310.0	329.0	310.0	329.0	220.0	130.0
maximum output torque(Nm)	620.0	208.0	620.0	658.0	620.0	658.0	620.0	658.0	620.0	658.0	620.0	658.0	440.0	260.0
Moment of inertia(Kgcm ²)	1.15	1.11	1.15	1.15	1.13	1.13	1.11	1.11	1.11	1.11	1.11	1.11	1.11	1.11

Subscript 1. Motor is different, matching size will vary, the adapter will be different. Our reducer can be matched to fix with any motor.
Subscript 2. Acting on the output shaft center (1/2 axis strengths), permitted radial force and axial force (be forced at the same time), when the output speed of 1-Stage reducer is 100rpm, or 2-stage's output speed is 50rpm, or 3-stage's output speed is 10rpm.

PLF120 precision planetary reducer

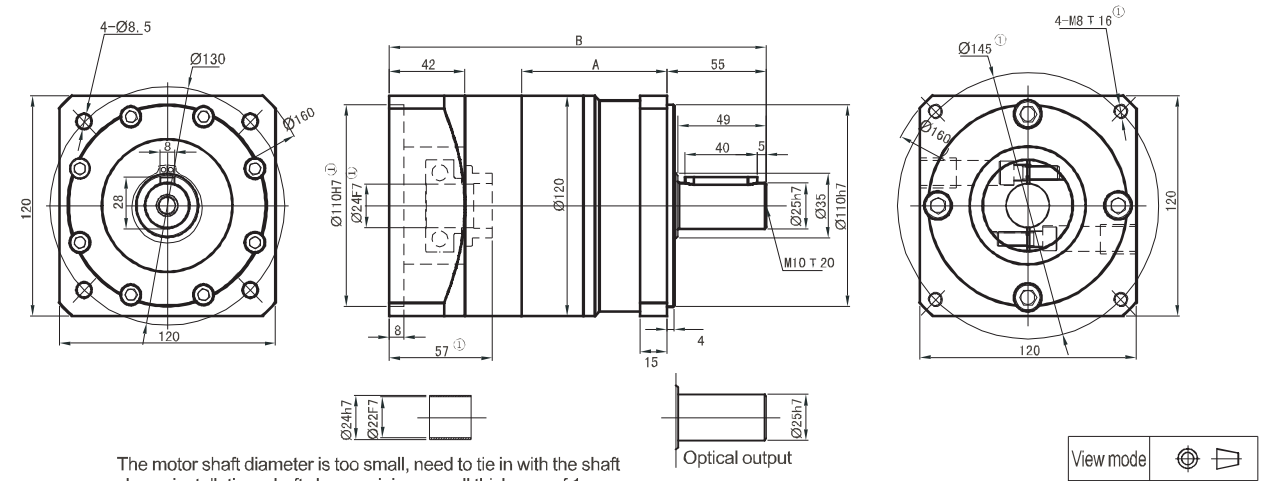

The motor shaft diameter is too small, need to tie in with the shaft sleeve installation, shaft sleeve minimum wall thickness of 1mm

Optical output

View mode

Stage	Stage 1 (Contains the speed ratio 3 4 5 7 10)		Stage 2 (Contains the speed ratio 12 16 20 25 28 35 40 50 70 100)				Stage 3 (Contains the speed ratio 80 100 125 140 175 200 250 350 400 500 700 1000)			
	A	B	A	B	A	B	A	B		
Length(mm)	80.5	209.0	112.0	240.5	143.5	272.0				
Rated input speed(rpm)	3000		3000				3000			
Maximum input speed(rpm)	4800		4800				4800			
The maximum radial force(N) ^②	2230		2840				3020			
The maximum axial force(N) ^②	1550		2100				2600			
No load torque(Nm)	About 1.3		About 0.6				About 0.6			
Efficiency with full load(%)	96		94				90			
Back lash(arcmin)	Precision: <3	Standard: <8	Precision: <5	Standard: <10	Precision: <8	Standard: <12				
Noise(dB)	≤65		≤65				≤65			
Weight(Kg)	6.9		8.9				11.2			
Average lifetime(h)	>20000									
Torsional rigidity(Nm/arcmin)	15.0									
lubricant	Effective lubrication									
direction of rotation	The input and output to the same									
Protection level	IP65									
Installation	arbitrarily									

Ratio(i)	3 ^①	4	5	7	10	12 ^①	16	20	25	28	35	40	50	70
Rated output torque(Nm)	148.0	222.0	235.0	158.0	93.0	250.0	250.0	250.0	264.0	250.0	264.0	250.0	264.0	177.0
maximum output torque(Nm)	296.0	444.0	470.0	316.0	186.0	500.0	500.0	500.0	528.0	500.0	528.0	500.0	528.0	354.0
Moment of inertia(Kgcm ²)	1.65	1.22	1.15	1.13	1.11	1.65	1.22	1.15	1.15	1.13	1.13	1.11	1.11	1.11

Ratio(i)	80	100 ^②	100 ^③	125	140	175	200	250	280	350	400	500	700	1000
Rated output torque(Nm)	310.0	104.0	310.0	329.0	310.0	329.0	310.0	329.0	310.0	329.0	310.0	329.0	220.0	130.0
maximum output torque(Nm)	620.0	208.0	620.0	658.0	620.0	658.0	620.0	658.0	620.0	658.0	620.0	658.0	440.0	260.0
Moment of inertia(Kgcm ²)	1.15	1.11	1.15	1.15	1.13	1.13	1.11	1.11	1.11	1.11	1.11	1.11	1.11	1.11

Subscript 1. Motor is different, matching size will vary, the adapter will be different. Our reducer can be matched to fix with any motor.
Subscript 2. Acting on the output shaft center (1/2 axis strengths), permitted radial force and axial force (be forced at the same time), when the output speed of 1-Stage reducer is 100rpm, or 2-stage's output speed is 50rpm, or 3-stage's output speed is 10rpm.

PLS120 precision planetary reducer

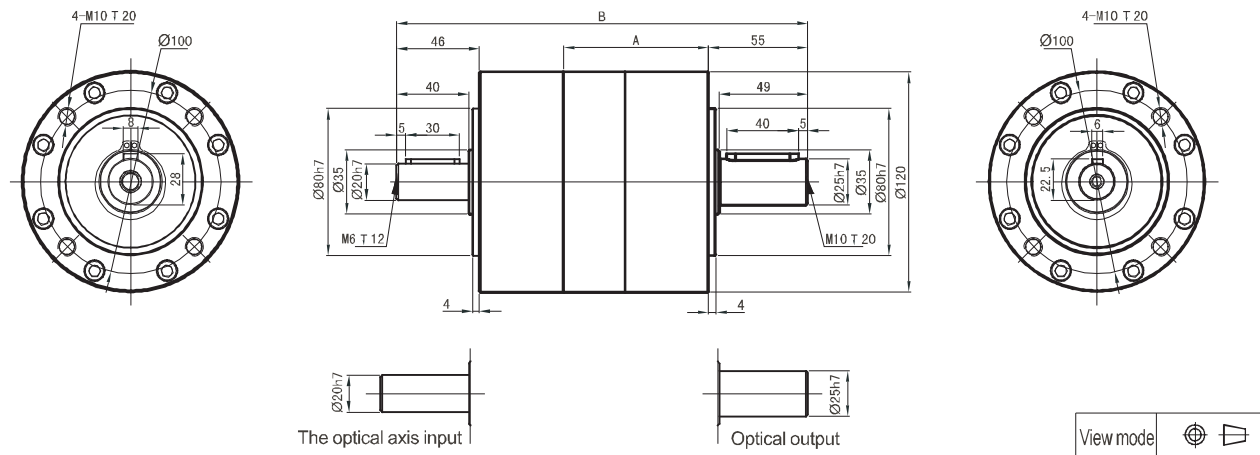

Stage	Stage 1 (Contains the speed ratio 3 4 5 7 10)		Stage 2 (Contains the speed ratio 12 16 20 25 28 35 40 50 70 100)				Stage 3 (Contains the speed ratio 80 100 125 140 175 200 250 330 400 500 700 1000)			
	A	B	A	B	A	B	A	B	A	B
Length(mm)	80.5	228	112.0	259.5	143.5	291.0				
Rated input speed(rpm)	3000		3000				3000			
Maximum input speed(rpm)	4800		4800				4800			
The maximum radial force(N) ^②			690							
The maximum axial force(N) ^②			420							
No load torque(Nm)	About 1.3		About 0.6				About 0.6			
Efficiency with full load(%)	96		94				90			
Back lash(arcmin)	Precision: <3	Standard: <8	Precision: <5	Standard: <10	Precision: <8	Standard: <12				
Noise(dB)	≤65		≤65				≤65			
Weight(Kg)	7.0		9.0				11.3			
Average lifetime(h)	>20000									
Torsional rigidity(Nm/arcmin)	15.0									
lubricant	Effective lubrication									
direction of rotation	The input and output to the same									
Protection level	IP65									
Installation	arbitrarily									

Ratio(i)	3 ^②	4	5	7	10	12 ^②	16	20	25	28	35	40	50	70
Rated output torque(Nm)	148.0	222.0	235.0	158.0	93.0	250.0	250.0	250.0	264.0	250.0	264.0	250.0	264.0	177.0
maximum output torque(Nm)	296.0	444.0	470.0	316.0	186.0	500.0	500.0	500.0	528.0	500.0	528.0	500.0	528.0	354.0
Moment of inertia(Kgcm ²)	1.19	0.80	0.71	0.68	0.67	1.19	0.80	0.71	0.71	0.68	0.68	0.67	0.67	0.67

Ratio(i)	80	100 ^②	100 ^③	125	140	175	200	250	280	350	400	500	700	1000
Rated output torque(Nm)	310.0	104.0	310.0	329.0	310.0	329.0	310.0	329.0	310.0	329.0	310.0	329.0	220.0	130.0
maximum output torque(Nm)	620.0	208.0	620.0	658.0	620.0	658.0	620.0	658.0	620.0	658.0	620.0	658.0	440.0	260.0
Moment of inertia(Kgcm ²)	0.71	0.67	0.71	0.71	0.68	0.68	0.67	0.67	0.67	0.67	0.67	0.67	0.67	0.67

Subscript 1. In the input speed is 2000rpm, is applied to the input shaft center (1/2 axis strengths) the measured radial force and axial force (allowable stress at the same time). The output force with PLE120.

ZPLE120 precision planetary reducer

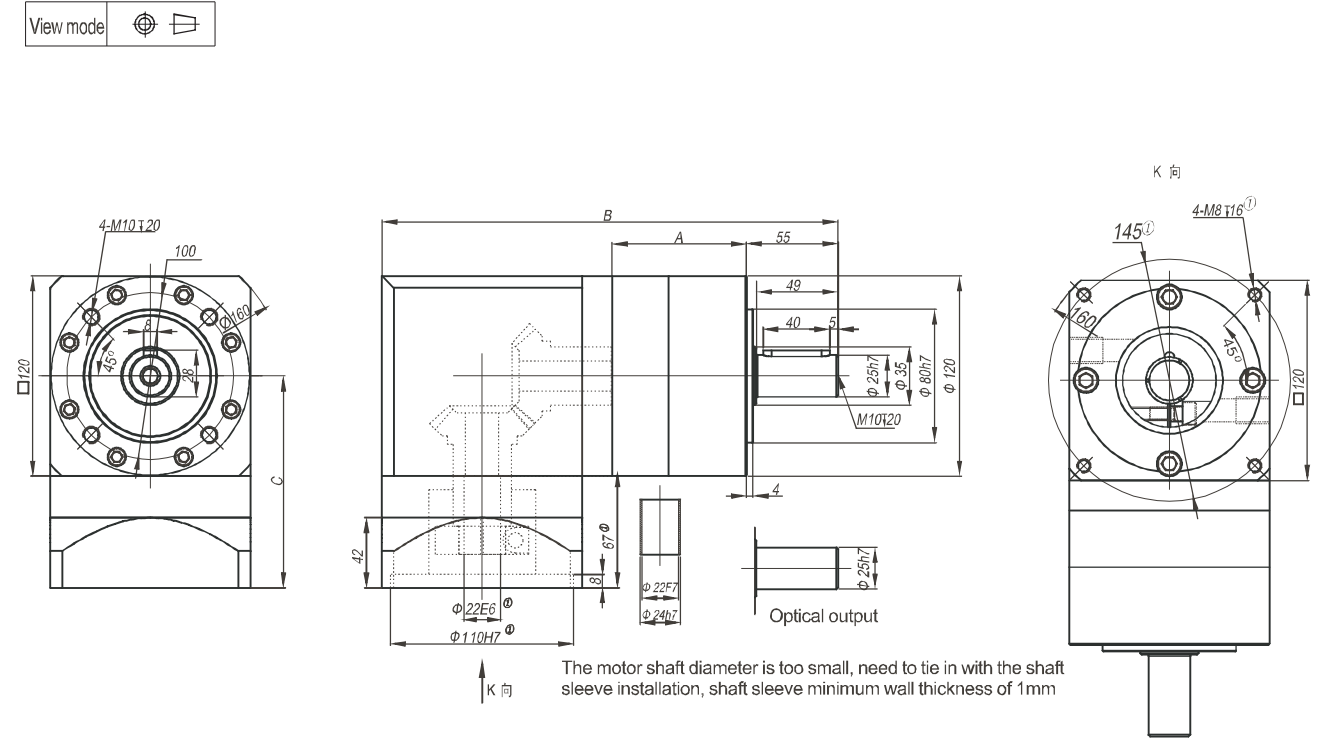

Stage	Stage 1 (Contains the speed ratio 3 4 5 7 10)			Stage 2 (Contains the speed ratio 12 16 20 25 28 35 40 50 70 100)			Stage 3 (Contains the speed ratio 80 100 125 140 175 200 250 330 400 500 700 1000)		
	A	B	C	A	B	C	A	B	C
Length(mm)	80.5	273.5	127.0	112.0	305.0	127.0	143.5	336.5	127.0
No load torque(Nm)	About 1.3			About 0.6			About 0.6		
Efficiency with full load(%)	95			93			90		
Back lash(arcmin)	Precision: <4	Standard: <10		Precision: <6	Standard: <13		Precision: <8	Standard: <16	
Noise(dB)	≤65			≤65			≤65		
Weight(Kg)	11.5			13.5			15.7		
direction of rotation	Input and output in different directions								

Not listed parameters refer to the PLE120 (including the maximum radial force rated input speed, the maximum input speed \ maximum axial force, the average life expectancy, torsional rigidity, lubricating oil, protection grade, installation, reduction ratio, rated output torque, maximum output torque, moment of inertia)

Subscript 1. Motor without, with matching size will vary, the adapter will be different. The company can be arranged to match with any motor speed reducer.

ZPLF120 precision planetary reducer

View mode

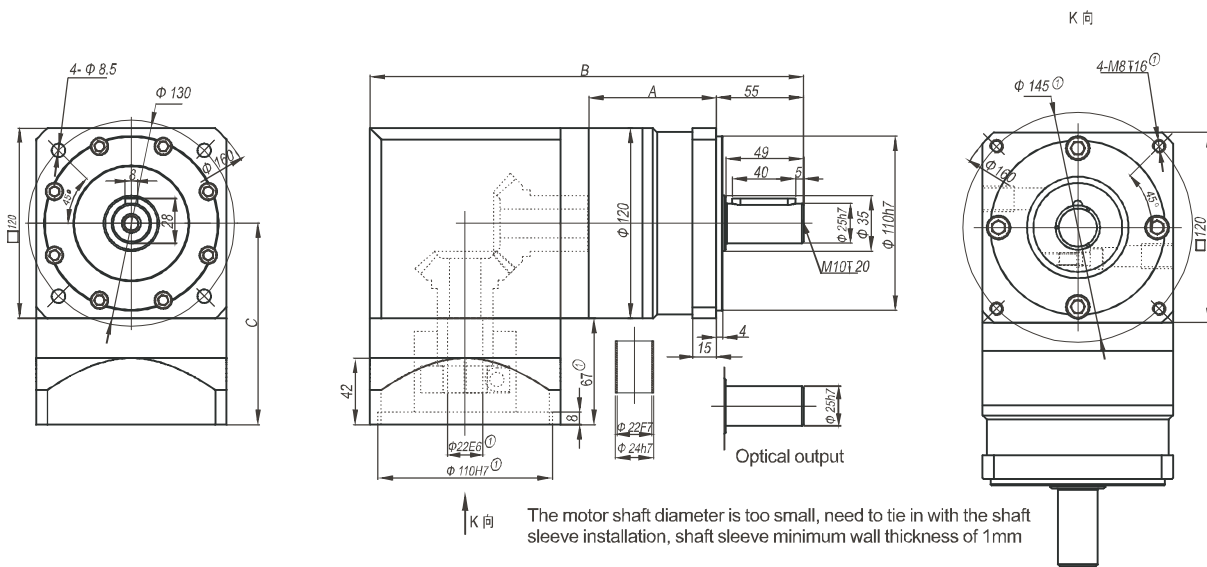

Stage	Stage 1 (Contains the speed ratio 3 4 5 7 10)			Stage 2 (Contains the speed ratio 12 16 20 25 28 35 40 50 70 100)			Stage 3 (Contains the speed ratio 80 100 125 140 175 200 250 350 400 500 700 1000)		
	A	B	C	A	B	C	A	B	C
Length(mm)	80.5	273.5	127.0	112.0	305.0	127.0	143.5	336.5	127.0
No load torque(Nm)	About 1.3			About 0.6			About 0.6		
Efficiency with full load(%)	95			93			90		
Back lash(arcmin)	Precision: <4	Standard: <10		Precision: <6	Standard: <13		Precision: <8	Standard: <16	
Noise(dB)	≤65			≤65			≤65		
Weight(Kg)	11.7			13.7			16.0		
direction of rotation	Input and output in different directions								

Not listed parameters refer to the PLE120 (including the maximum radial force rated input speed, the maximum input speed \ maximum axial force, the average life expectancy, torsional rigidity, lubricating oil, protection grade, installation, reduction ratio, rated output torque, maximum output torque, moment of inertia)

Subscript 1. Motor without, with matching size will vary, the adapter will be different. The company can be arranged to match with any motor speed reducer.

PLH120 precision planetary reducer

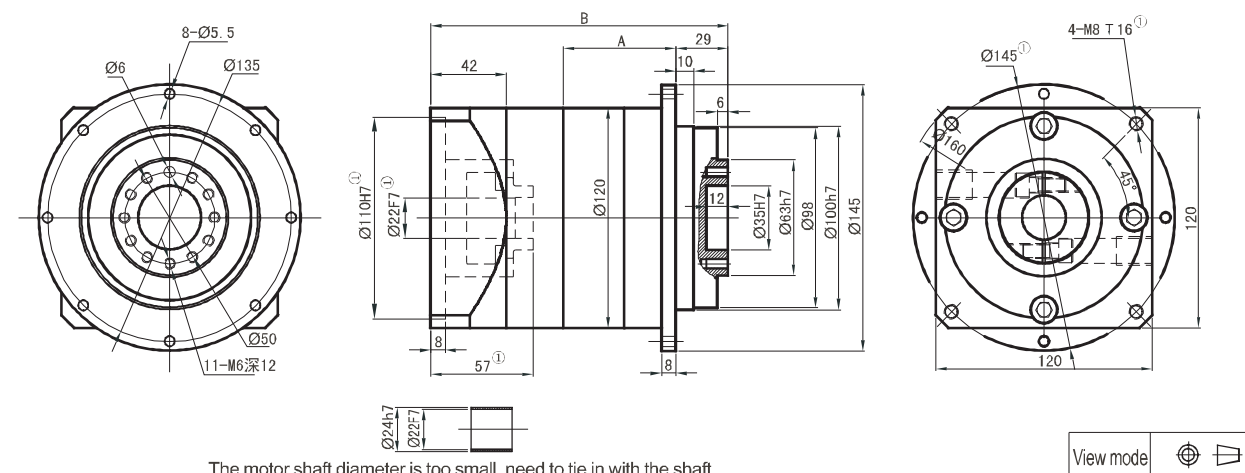

Stage	Stage 1 (Contains the speed ratio 3 4 5 7 10)			Stage 2 (Contains the speed ratio 12 16 20 25 28 35 40 50 70 100)			Stage 3 (Contains the speed ratio 80 100 125 140 175 200 250 350 400 500 700 1000)		
	A	B	C	A	B	C	A	B	C
Length(mm)	62.5	165.0		94.0	196.5		128.5	231.0	
Rated input speed(rpm)	3000			3000			3000		
Maximum input speed(rpm)	4800			4800			4800		
The maximum radial force(N) ^②	1300			1800			3300		
The maximum axial force(N) ^②	900			1200			2000		
No load torque(Nm)	About 1.3			About 0.6			About 0.6		
Efficiency with full load(%)	96			94			90		
Back lash(arcmin)	Precision: <3	Standard: <8		Precision: <5	Standard: <10		Precision: <8	Standard: <12	
Noise(dB)	≤65			≤65			≤65		
Weight(Kg)	8.1			10.3			12.5		
Average lifetime(h)	>20000								
Torsional rigidity(Nm/arcmin)	8.9								
lubricant	Effective lubrication								
direction of rotation	The input and output to the same								
Protection level	IP65								
Installation	arbitrarily								

Ratio(1)	3 ^{①②}	4	5	7	10	12 ^{①②}	16	20	25	28	35	40	50	70
Rated output torque(Nm)	148.0	222.0	235.0	158.0	93.0	250.0	250.0	250.0	264.0	250.0	264.0	250.0	264.0	177.0
maximum output torque(Nm)	296.0	444.0	470.0	316.0	186.0	500.0	500.0	500.0	528.0	500.0	528.0	500.0	528.0	354.0
Moment of inertia(Kgcm ²)	1.65	1.22	1.15	1.13	1.11	1.65	1.22	1.15	1.15	1.13	1.13	1.11	1.11	1.11

Ratio(1)	80	100 ^{①②}	100 ^{①③}	125	140	175	200	250	280	350	400	500	700	1000
Rated output torque(Nm)	310.0	104.0	310.0	329.0	310.0	329.0	310.0	329.0	310.0	329.0	310.0	329.0	220.0	130.0
maximum output torque(Nm)	620.0	208.0	620.0	658.0	620.0	658.0	620.0	658.0	620.0	658.0	620.0	658.0	440.0	260.0
Moment of inertia(Kgcm ²)	1.15	1.11	1.15	1.15	1.13	1.13	1.11	1.11	1.11	1.11	1.11	1.11	1.11	1.11

Subscript 1. Motor is different, matching size will vary, the adapter will be different. Our reducer can be matched to fix with any motor.
Subscript 2. Acting on the output shaft center (1/2 axis strengths), permitted radial force and axial force (be forced at the same time), when the output speed of 1-Stage reducer is 100rpm, or 2-stage's output speed is 50rpm, or 3-stage's output speed is 10rpm.

PLE160 precision planetary reducer

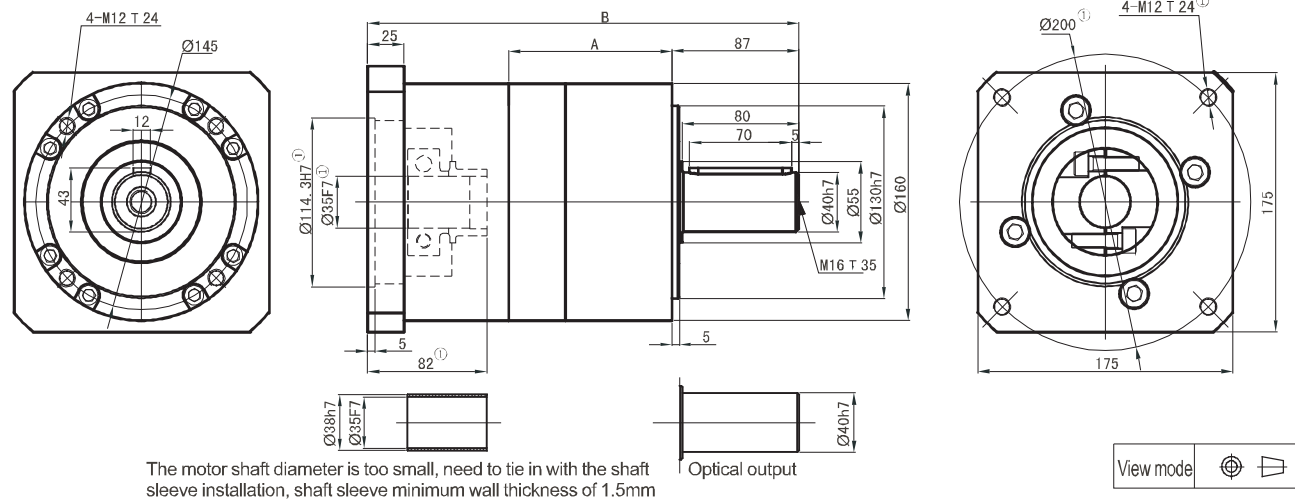

Stage	Stage 1 (Contains the speed ratio 3 4 5 8)		Stage 2 (Contains the speed ratio 9 12 16 20 25 32 40 64)				Stage 3 (Contains the speed ratio 60 80 100 120 160 200 256 320 512)			
	A	B	A	B	A	B	A	B		
Length(mm)	112.0	296.0	151.0	335.0	190.0	374.0				
Rated input speed(rpm)	3000		3000				3000			
Maximum input speed(rpm)	4500		4500				4500			
The maximum radial force(N) ^②	2200		2700				4650			
The maximum axial force(N) ^②	2300		3000				6200			
No load torque(Nm)	About 3. 2		About 2. 1				About 2. 1			
Efficiency withfull load(%)	96		94				90			
Back lash(arcmin)	Precision: <3	Standard: <8	Precision: <5	Standard: <10	Precision: <8	Standard: <12				
Noise(dB)	≤68		≤68				≤68			
Weight(Kg)	19. 0		25. 0				31. 0			
Average lifetime(h)	>20000									
Torsional rigidity(Nm/arcmin)	27. 0									
lubricant	Effective lubrication									
direction of rotation	The input and output to the same									
Protection level	IP65									
Installation	arbitrarily									

Ratio(i)	3	4	5	8	12	16	20	25	32	40	60	64	80	100
Rated output torque(Nm)	310.0	605.0	420.0	270.0	680.0	680.0	680.0	460.0	680.0	460.0	900.0	310.0	900.0	900.0
maximum output torque(Nm)	620.0	1210.0	840.0	540.0	1360.0	136.0	1360.0	920.0	1360.0	920.0	1800.0	620.0	1800.0	1800.0
Moment of inertia(Kgcm ²)	6.31	5.15	4.93	4.84	6.31	5.15	4.93	4.93	4.84	4.84	9.31	4.84	4.93	4.93

Ratio(i)	120	160	200	256	320	512
Rated output torque(Nm)	580.0	900.0	580.0	900.0	580.0	400.0
maximum output torque(Nm)	1160.0	1800.0	1160.0	1800.0	1160.0	800.0
Moment of inertia(Kgcm ²)	4.84	4.84	4.84	4.84	4.84	4.84

Subscript 1. Motor is different, matching size will vary, the adapter will be different. Our reducer can be matched to fix with any motor.
 Subscript 2. Acting on the output shaft center (1/2 axis strengths), permitted radial force and axial force (be forced at the same time), when the output speed of 1-Stage reducer is 100rpm, or 2-stage's output speed is 50rpm, or 3-stage's output speed is 10rpm.

PLF160 precision planetary reducer

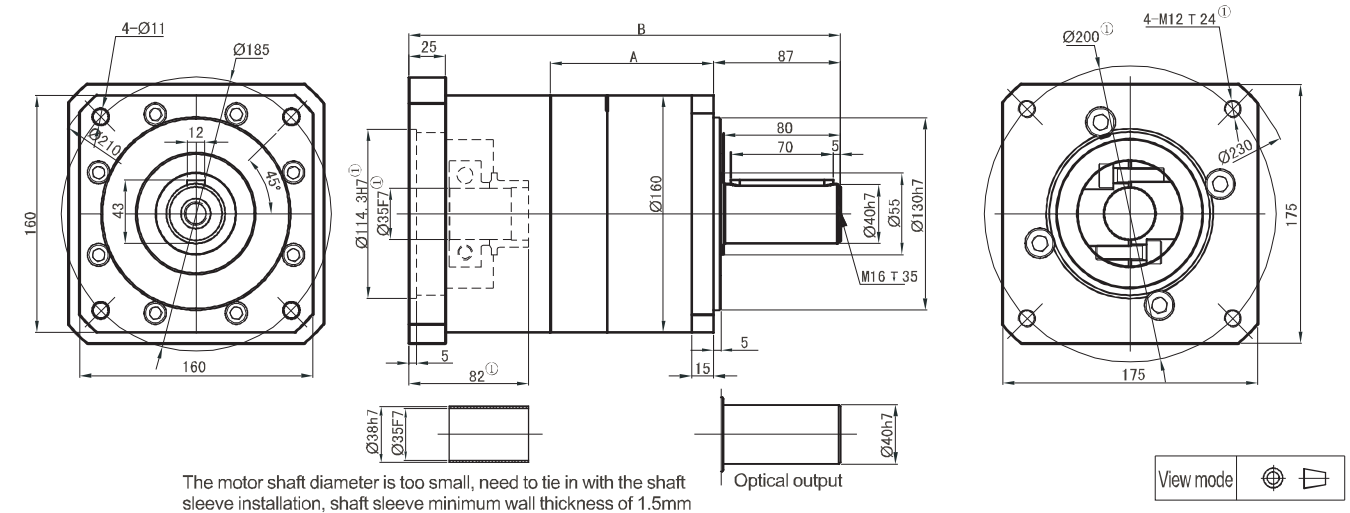

Stage	Stage 1 (Contains the speed ratio 3 4 5 8)		Stage 2 (Contains the speed ratio 9 12 16 20 25 32 40 64)				Stage 3 (Contains the speed ratio 60 80 100 120 160 200 256 320 512)			
	A	B	A	B	A	B	A	B		
Length(mm)	112.0	296.0	151.0	335.0	190.0	374.0				
Rated input speed(rpm)	3000		3000				3000			
Maximum input speed(rpm)	4500		4500				4500			
The maximum radial force(N) ^②	2200		2700				4650			
The maximum axial force(N) ^②	2300		3000				6000			
No load torque(Nm)	About 3. 2		About 2. 1				About 2. 1			
Efficiency withfull load(%)	96		94				90			
Back lash(arcmin)	Precision: <3	Standard: <8	Precision: <5	Standard: <10	Precision: <8	Standard: <12				
Noise(dB)	≤68		≤68				≤68			
Weight(Kg)	19. 5		25. 5				31. 5			
Average lifetime(h)	>20000									
Torsional rigidity(Nm/arcmin)	27. 0									
lubricant	Effective lubrication									
direction of rotation	The input and output to the same									
Protection level	IP65									
Installation	arbitrarily									

Ratio(i)	3	4	5	8	12	16	20	25	32	40	60	64	80	100
Rated output torque(Nm)	310.0	605.0	420.0	270.0	680.0	680.0	680.0	460.0	680.0	460.0	900.0	310.0	900.0	900.0
maximum output torque(Nm)	620.0	1210.0	840.0	540.0	1360.0	136.0	1360.0	920.0	1360.0	920.0	1800.0	620.0	1800.0	1800.0
Moment of inertia(Kgcm ²)	6.31	5.15	4.93	4.84	6.31	5.15	4.93	4.93	4.84	4.84	9.31	4.84	4.93	4.93

Ratio(i)	120	160	200	256	320	512
Rated output torque(Nm)	580.0	900.0	580.0	900.0	580.0	400.0
maximum output torque(Nm)	1160.0	1800.0	1160.0	1800.0	1160.0	800.0
Moment of inertia(Kgcm ²)	4.84	4.84	4.84	4.84	4.84	4.84

Subscript 1. Motor is different, matching size will vary, the adapter will be different. Our reducer can be matched to fix with any motor.
 Subscript 2. Acting on the output shaft center (1/2 axis strengths), permitted radial force and axial force (be forced at the same time), when the output speed of 1-Stage reducer is 100rpm, or 2-stage's output speed is 50rpm, or 3-stage's output speed is 10rpm.

PLS160 precision planetary reducer

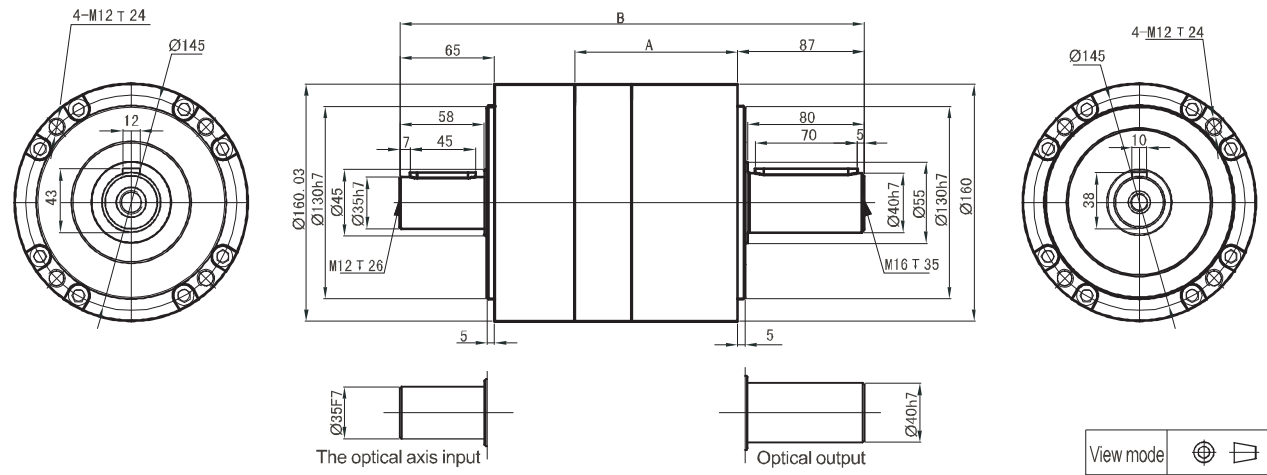

Stage	Stage 1 (Contains the speed ratio 3 4 5 8)		Stage 2 (Contains the speed ratio 9 12 16 20 25 32 40 64)				Stage 3 (Contains the speed ratio 60 80 100 120 160 200 256 320 512)			
	A	B	A	B	A	B	A	B		
Length(mm)	112.0	319.0	151.0	358.0	190.0	397.0				
Rated input speed(rpm)	3000		3000				3000			
Maximum input speed(rpm)	4500		4500				4500			
The maximum radial force(N) ^②			1400							
The maximum axial force(N) ^②			900							
No load torque(Nm)	About 3.2		About 2.1				About 2.1			
Efficiency withfull load(%)	96		94				90			
Back lash(arcmin)	Precision: <3	Standard: <8	Precision: <5	Standard: <10	Precision: <8	Standard: <12				
Noise(dB)	≤65		≤65				≤65			
Weight(Kg)	25.0		31.0				37.0			
Average lifetime(h)	>20000									
Torsional rigidity(Nm/arcmin)	27.0									
lubricant	Effective lubrication									
direction of rotation	The input and output to the same									
Protection level	IP65									
Installation	arbitrarily									

Ratio(i)	3	4	5	8	12	16	20	25	32	40	60	64	80	100
Rated output torque(Nm)	310.0	605.0	420.0	270.0	680.0	680.0	680.0	460.0	680.0	460.0	900.0	310.0	900.0	900.0
maximum output torque(Nm)	620.0	1210.0	840.0	540.0	1360.0	136.0	1360.0	920.0	1360.0	920.0	1800.0	620.0	1800.0	1800.0
Moment of inertia(Kgcm ²)	4.41	3.26	3.08	2.96	4.41	3.26	3.08	3.08	2.94	2.94	4.41	2.96	3.08	3.08

Ratio(i)	120	160	200	256	320	512
Rated output torque(Nm)	580.0	900.0	580.0	900.0	580.0	400.0
maximum output torque(Nm)	1160.0	1800.0	1160.0	1800.0	1160.0	800.0
Moment of inertia(Kgcm ²)	2.96	2.96	2.96	2.96	2.96	2.96

Subscript 1. In the input speed is 2000rpm, is applied to the input shaft center (1/2 axis strengths) the measured radial force and axial force (allowable stress at the same time). The output force with PLE160.

PLH160 precision planetary reducer

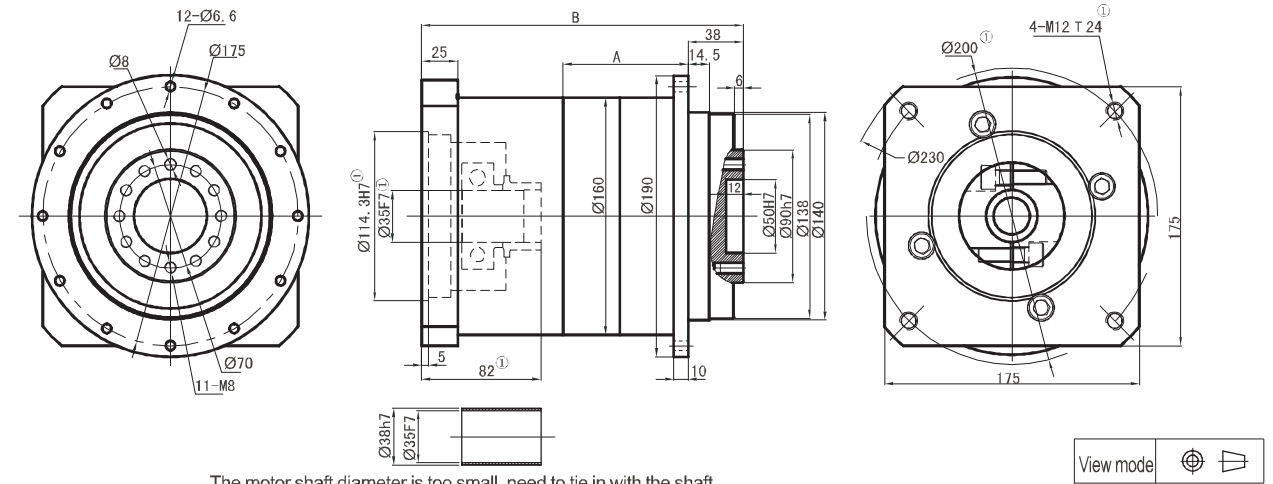

The motor shaft diameter is too small, need to tie in with the shaft sleeve installation, shaft sleeve minimum wall thickness of 1.5mm

Stage	Stage 1 (Contains the speed ratio 3 4 5 8)		Stage 2 (Contains the speed ratio 9 12 16 20 25 32 40 64)				Stage 3 (Contains the speed ratio 60 80 100 120 160 200 256 320 512)			
	A	B	A	B	A	B	A	B		
Length(mm)	86.0	221.0	125.0	260.0	169.0	299.0				
Rated input speed(rpm)	3000		3000				3000			
Maximum input speed(rpm)	4500		4500				4500			
The maximum radial force(N) ^②	2600		3400				6300			
The maximum axial force(N) ^②	1800		2300				4000			
No load torque(Nm)	About 3.2		About 2.1				About 2.1			
Efficiency withfull load(%)	96		94				90			
Back lash(arcmin)	Precision: <3	Standard: <8	Precision: <5	Standard: <10	Precision: <8	Standard: <12				
Noise(dB)	≤68		≤68				≤68			
Weight(Kg)	22.5		28.5				34.5			
Average lifetime(h)	>20000									
Torsional rigidity(Nm/arcmin)	25.0									
lubricant	Effective lubrication									
direction of rotation	The input and output to the same									
Protection level	IP65									
Installation	arbitrarily									

Ratio(i)	3	4	5	8	12	16	20	25	32	40	60	64	80	100
Rated output torque(Nm)	310.0	605.0	420.0	270.0	680.0	680.0	680.0	460.0	680.0	460.0	900.0	310.0	900.0	900.0
maximum output torque(Nm)	620.0	1210.0	840.0	540.0	1360.0	136.0	1360.0	920.0	1360.0	920.0	1800.0	620.0	1800.0	1800.0
Moment of inertia(Kgcm ²)	6.31	5.15	4.93	4.84	6.31	5.15	4.93	4.93	4.84	4.84	6.31	4.84	4.93	4.93

Ratio(i)	120	160	200	256	320	512
Rated output torque(Nm)	580.0	900.0	580.0	900.0	580.0	400.0
maximum output torque(Nm)	1160.0	1800.0	1160.0	1800.0	1160.0	800.0
Moment of inertia(Kgcm ²)	4.84	4.84	4.84	4.84	4.84	4.84

Subscript 1. Motor is different, matching size will vary, the adapter will be different. Our reducer can be matched to fix with any motor.
Subscript 2. Acting on the output shaft center (1/2 axis strengths), permitted radial force and axial force (be forced at the same time), when the output speed of 1-Stage reducer is 100rpm, or 2-stage's output speed is 50rpm, or 3-stage's output speed is 10rpm.

PLX142 precision planetary reducer

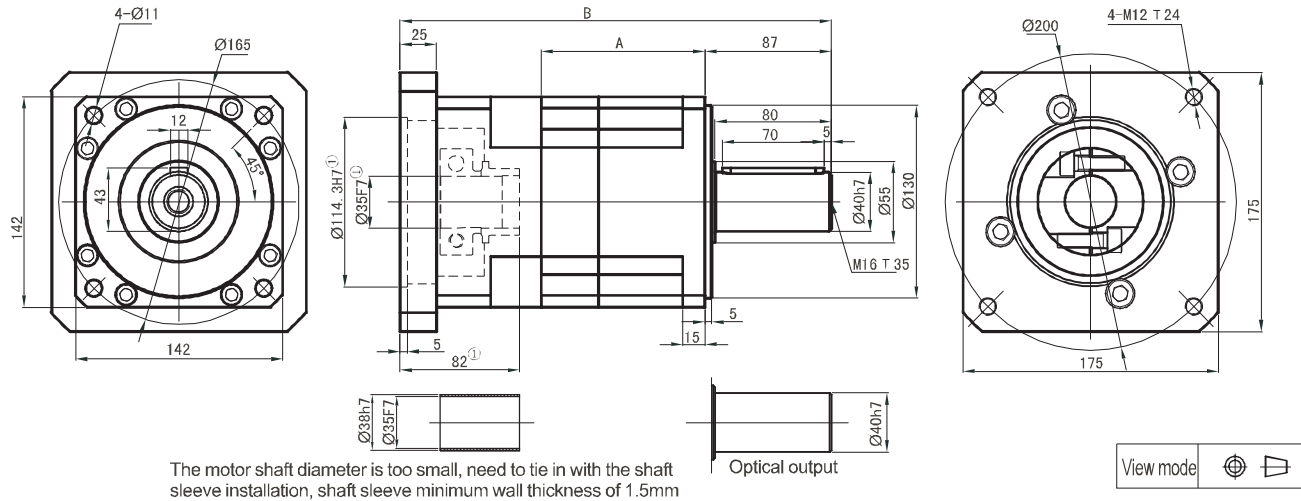

Stage	Stage 1 (Contains the speed ratio 3 4 5 8)		Stage 2 (Contains the speed ratio 9 12 16 20 25 32 40 64)		Stage 3 (Contains the speed ratio 60 80 100 120 160 200 256 320 512)	
	A	B	A	B	A	B
Length(mm)	112.0	296.0	151.0	335.0	190.0	374.0
Rated input speed(rpm)	3000		3000		3000	
Maximum input speed(rpm)	4500		4500		4500	
The maximum radial force(N) ^②	2200		2700		4650	
The maximum axial force(N) ^②	2300		3000		6200	
No load torque(Nm)	About 3.2		About 2.1		About 2.1	
Efficiency withfull load(%)	96		94		90	
Back lash(arcmin)	Precision: <3	Standard: <8	Precision: <5	Standard: <10	Precision: <8	Standard: <12
Noise(dB)	≤68		≤68		≤68	
Weight(Kg)	17.0		23.0		29.0	
Average lifetime(h)	>20000					
Torsional rigidity(Nm/arcmin)	27.0					
lubricant	Effective lubrication					
direction of rotation	The input and output to the same					
Protection level	IP65					
Installation	arbitrarily					

Ratio(i)	3	4	5	8	12	16	20	25	32	40	60	64	80	100
Rated output torque(Nm)	310.0	605.0	420.0	270.0	680.0	680.0	680.0	460.0	680.0	460.0	900.0	310.0	900.0	900.0
maximum output torque(Nm)	620.0	1210.0	840.0	540.0	1360.0	136.0	1360.0	920.0	1360.0	920.0	1800.0	620.0	1800.0	1800.0
Moment of inertia(Kgcm ²)	6.31	5.15	4.93	4.84	6.31	5.15	4.93	4.93	4.84	4.84	6.31	4.84	4.93	4.93

Ratio(i)	120	160	200	256	320	512
Rated output torque(Nm)	580.0	900.0	580.0	900.0	580.0	400.0
maximum output torque(Nm)	1160.0	1800.0	1160.0	1800.0	1160.0	800.0
Moment of inertia(Kgcm ²)	4.84	4.84	4.84	4.84	4.84	4.84

Subscript 1. Motor is different, matching size will vary, the adapter will be different. Our reducer can be matched to fix with any motor.
 Subscript 2. Acting on the output shaft center (1/2 axis strengths), permitted radial force and axial force (be forced at the same time), when the output speed of 1-stage reducer is 100rpm, or 2-stage's output speed is 50rpm, or 3-stage's output speed is 10rpm.

ZPLX142 precision planetary reducer

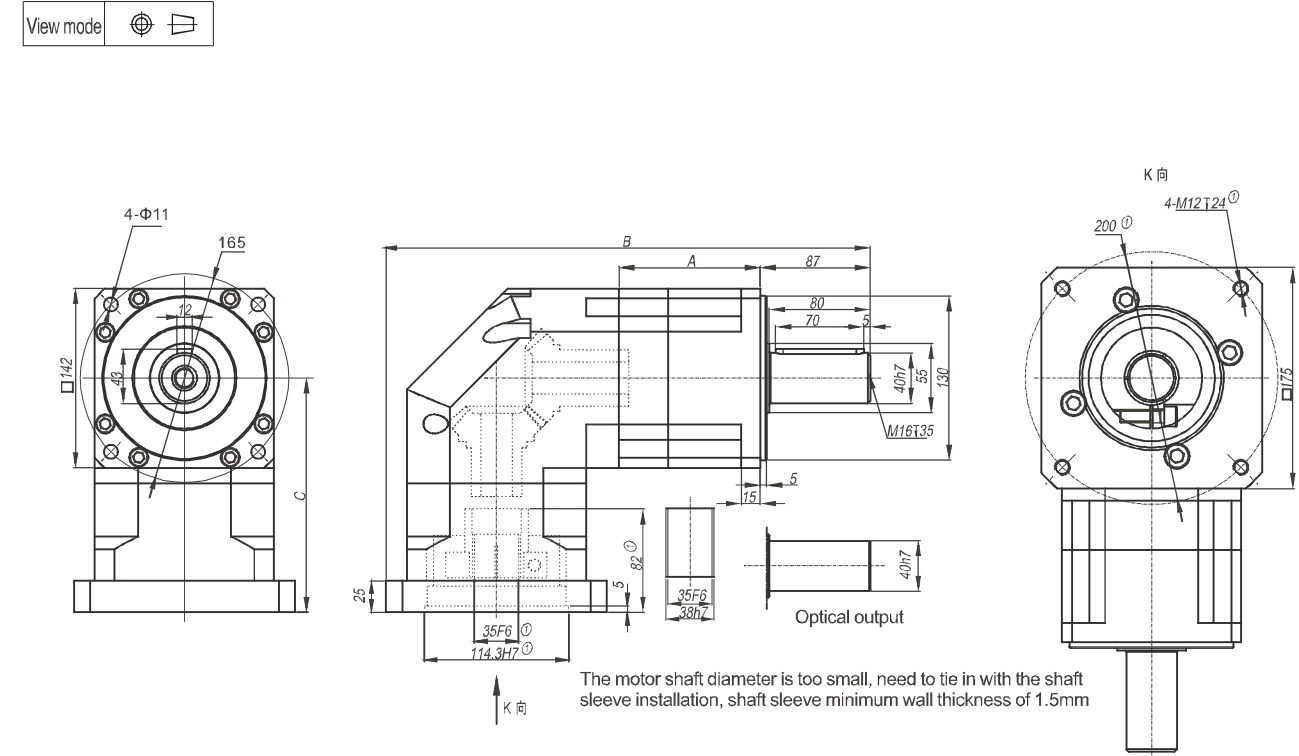

Stage	Stage 1 (Contains the speed ratio 3 4 5 8)			Stage 2 (Contains the speed ratio 9 12 16 20 25 32 40 64)			Stage 3 (Contains the speed ratio 60 80 100 120 160 200 256 320 512)		
	A	B	C	A	B	C	A	B	C
Length(mm)	112.0	383.5	185.5	151.0	422.5	185.5	190.0	461.5	185.5
No load torque(Nm)	About 3.2			About 2.1			About 2.1		
Efficiency withfull load(%)	95			93			90		
Back lash(arcmin)	Precision: <4	Standard: <10		Precision: <6	Standard: <13		Precision: <8	Standard: <16	
Noise(dB)	≤68			≤68			≤68		
Weight(Kg)	26.5			31.5			37.5		
direction of rotation	Input and output in different directions								

Not listed parameters refer to the PLX142 (including the maximum radial force rated input speed, the maximum input speed \ maximum axial force, the average life expectancy, torsional rigidity, lubricating oil, protection grade, installation, reduction ratio, rated output torque, maximum output torque, moment of inertia)

Subscript 1. Motor without, with matching size will vary, the adapter will be different. The company can be arranged to match with any motor speed reducer.

AB series precision planetary gear box

Reducer performance parameters

Specifications	Unit	The number of segments	Ratio	AB60	AB90	AB115	AB142	AB180	AB220	AB280	AB340	AB400	
Rated output torque of T2N	Nm	L1	3	27.8	115	212	470	1226	1730	4230	8200	12500	
			4	46.32	142	268	582	1450	2270	5120	9800	16000	
			5	46.32	142	268	582	1450	2270	5120	8500	12200	
			7	38.9	110	212	468	1130	1610	3220	5000	7600	
			10	18.5	56	95	255	730	1050	1820	3500	5000	
		L2	15	46.32	142	268	582	1450	2270	5120	8500	16000	
			20	46.32	142	268	582	1450	2270	5120	9800	16000	
			25	46.32	142	268	582	1450	2270	5120	8500	12200	
			30	46.32	142	268	582	1450	2270	5120	8200	12500	
			35	46.32	142	268	582	1450	2270	5120	8500	12200	
			40	46.32	142	268	582	1450	2270	5120	9800	16000	
			50	46.32	142	268	582	1450	2270	5120	8500	12200	
			70	38.9	110	212	468	1130	1610	3220	5000	7600	
			100	18.5	56	95	255	730	1050	1820	3500	5000	
			L3	64	46.32	142	268	582	1450	2270	5120	9800	16000
		80		46.32	142	268	582	1450	2270	5120	9800	16000	
		100		46.32	142	268	582	1450	2270	5120	9800	16000	
		150		46.32	142	268	582	1450	2270	5120	8500	12200	
		200		46.32	142	268	582	1450	2270	5120	9800	16000	
		250		46.32	142	268	582	1450	2270	5120	8500	12200	
350	46.32	142		268	582	1450	2270	5120	8500	12200			
400	46.32	142		268	582	1450	2270	5120	9800	16000			
The maximum output torque of T2B	Nm	L1 L2 L3	3-1000	2 times the rated output torque									
	Rated input speed n1N	rpm	L1 L2 L3	3-1000	4000	3500	3500	3000	3000	2500	2000	1500	1500
	Maximum input speed n1B	rpm	L1 L2 L3	3-1000	8000	7000	7000	5000	5000	4000	3000	2000	2000
	Precision backlash P1	arcmin	L1	3-10	≤4	≤4	≤4	≤4	≤4	≤4	≤8	≤8	≤8
L2			9-100	≤6	≤6	≤6	≤6	≤6	≤6	≤12	≤12	≤12	
L3			64-1000	≤7	≤7	≤7	≤7	≤7	≤7	≤16	≤16	≤16	
Standard backlash P2	arcmin	L1	3-10	≤6	≤6	≤6	≤6	≤6	≤6	≤12	≤12	≤12	
		L2	9-100	≤8	≤8	≤8	≤8	≤8	≤8	≤18	≤18	≤18	
		L3	64-1000	≤10	≤10	≤10	≤10	≤10	≤10	≤24	≤24	≤24	
Permissible radial force F1	N	L1 L2 L3	3-1000	1550	3250	6700	9400	14500	50000	60000	70000	90000	
Allowable axial force F2	N	L1 L2 L3	3-1000	775	1625	3350	4700	7250	25000	30000	95000	125000	
service life	h	L1 L2 L3	3-1000	20000									
effectiveness η	%	L1	3-10	97%	97%	97%	97%	97%	97%	97%	97%	97%	
		L2	9-100	94%	94%	94%	94%	94%	94%	94%	94%	94%	
		L3	64-1000	91%	91%	91%	91%	91%	91%	91%	91%	91%	
weight	kg	L1	3-10	1.3	3.6	7.5	16.0	28.0	48.0	110	160.0	250.0	
		L2	9-100	1.5	4.2	9.5	20.0	32.0	60.0	135	190.0	340.0	
		L3	64-1000	1.8	4.8	11.5	24.0	36.0	72.0	150	225.0	420.0	
Noise	dB	L1 L2 L3	3-1000	≤58	≤60	≤65	≤70	≤70	≤75	≤75	≤75	≤75	
end-use temperature	°C	L1 L2 L3	3-1000	-20°C~+90°C									

Reducer rotating inertia:

Specifications	Unit	The number of segments	Ratio	AB60	AB90	AB115	AB142	AB180	AB220	AB280	AB340	AB400
Moment of inertia J	kg·cm ²	L1	3/4/5	0.18	0.75	2.85	12.4	15.3	34.8	44.9	80	255
			7-10	0.12	0.45	1.95	8.1	14.8	28.6	39.2	79	245
		L2	9-50	0.15	0.52	2.15	7.6	15.2	32.2	41.8	75	240
			70-100	0.072	0.38	1.85	6.9	14.6	26.7	32.6	72	230
		L3	64-350	0.07	0.36	2.05	6.3	14.2	18.3	28.1	68	220
			400-1000	0.065	0.29	1.65	4.3	12.6	13.7	22.5	62	210

AB060 precision planetary gear outline drawing

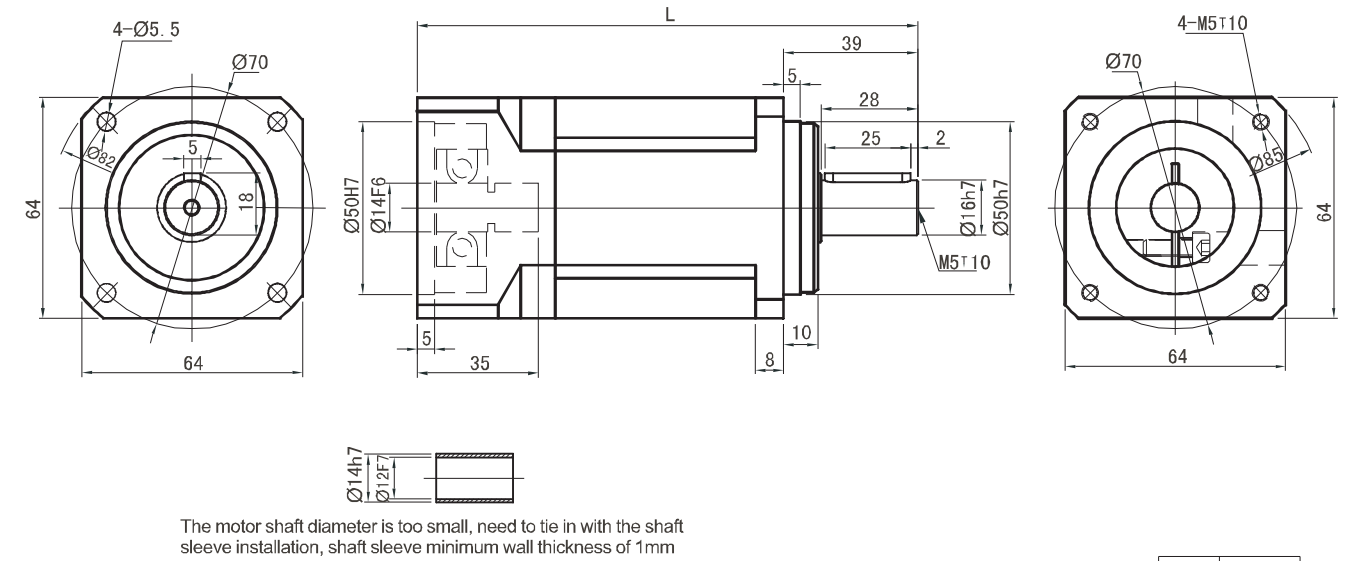

The motor shaft diameter is too small, need to tie in with the shaft sleeve installation, shaft sleeve minimum wall thickness of 1mm

View mode

Stage	Stage 1 (Contains the speed ratio 3 4 5 7 10)	Stage 2 (Contains the speed ratio 9 15 20 25 30 40 50 70 100)	Stage 3 (Contains the speed ratio 64 80 100 150 200 250 350 400 500 700 1000)
	L	L	L
Length(mm)	126.0	145.0	164.0

AB090 precision planetary gear outline drawing

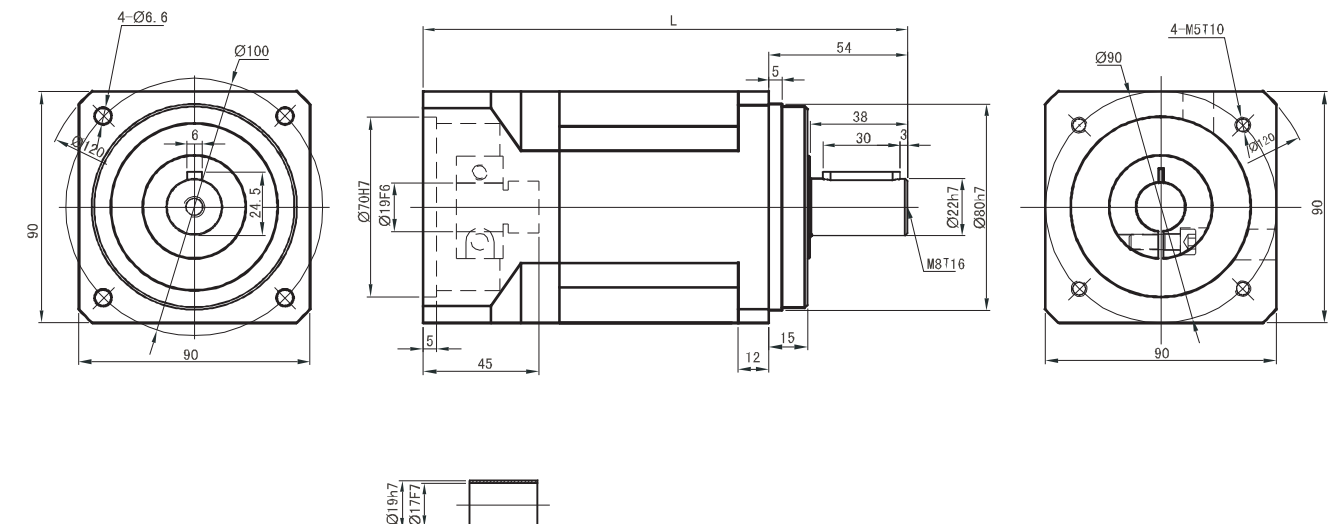

The motor shaft diameter is too small, need to tie in with the shaft sleeve installation, shaft sleeve minimum wall thickness of 1mm

View mode

Stage	Stage 1 (Contains the speed ratio 3 4 5 7 10)	Stage 2 (Contains the speed ratio 9 15 20 25 30 40 50 70 100)	Stage 3 (Contains the speed ratio 64 80 100 150 200 250 350 400 500 700 1000)
	L	L	L
Length(mm)	175.0	198.0	221.0

ABR115 precision planetary gear outline drawing

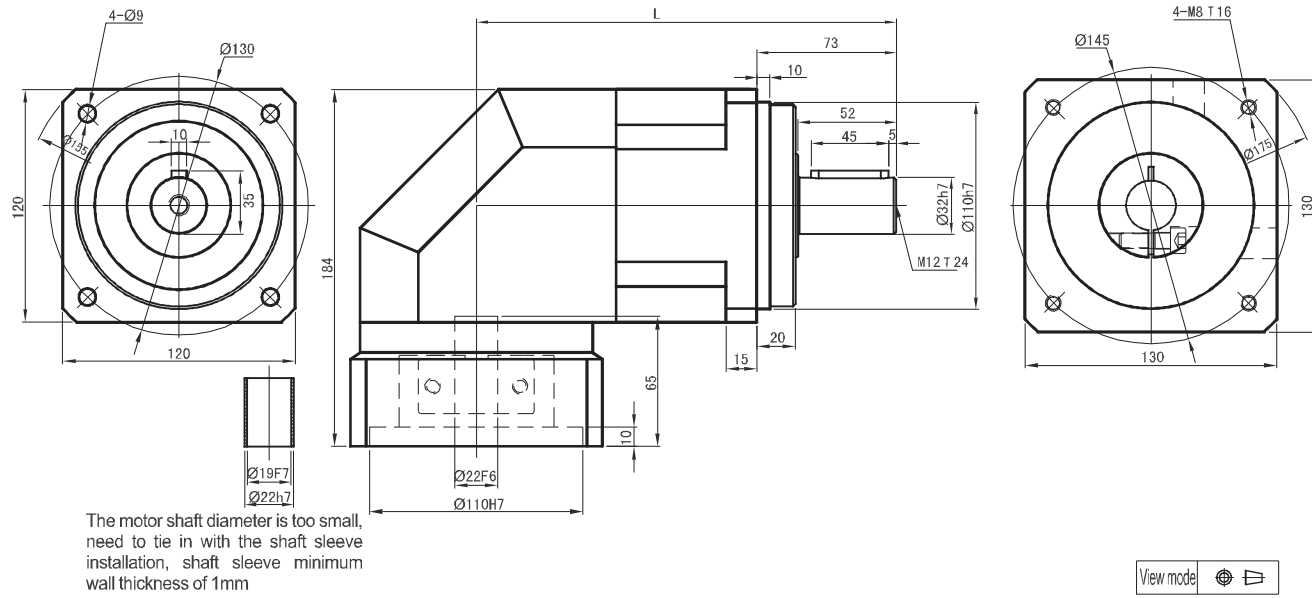

Stage	Stage 1 (Contains the speed ratio 3 4 5 7 10)	Stage 2 (Contains the speed ratio 9 15 20 25 30 40 50 70 100)	Stage 3 (Contains the speed ratio 64 80 100 150 200 250 350 400 500 700 1000)
	L	L	L
Length(mm)	141.2	173.2	195.2

ABR180 precision planetary gear outline drawing

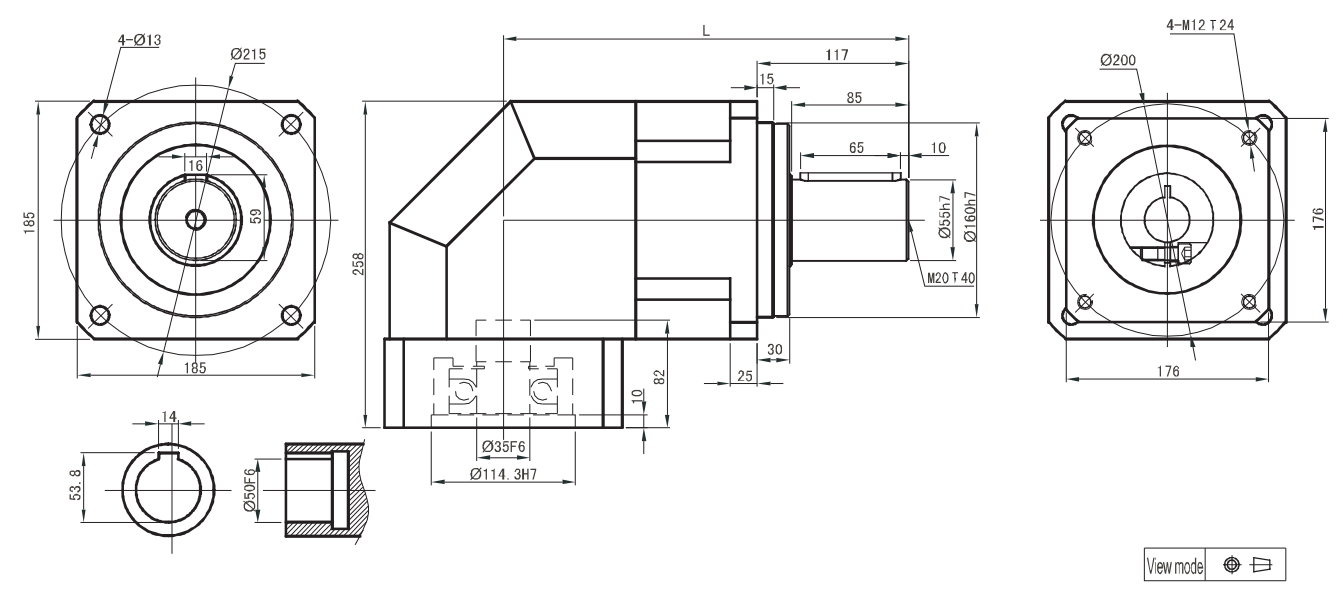

Stage	Stage 1 (Contains the speed ratio 3 4 5 7 10)	Stage 2 (Contains the speed ratio 9 15 20 25 30 40 50 70 100)	Stage 3 (Contains the speed ratio 64 80 100 150 200 250 350 400 500 700 1000)
	L	L	L
Length(mm)	206.0	235.0	280.0

ABR142 precision planetary gear outline drawing

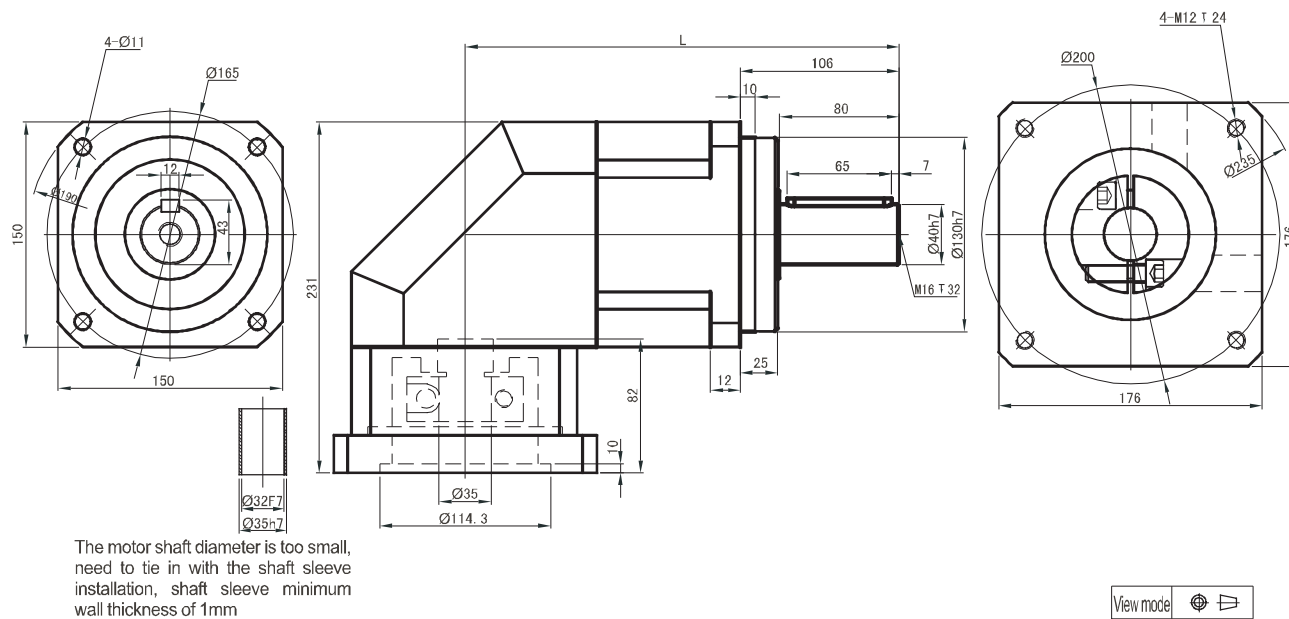

Stage	Stage 1 (Contains the speed ratio 3 4 5 7 10)	Stage 2 (Contains the speed ratio 9 15 20 25 30 40 50 70 100)	Stage 3 (Contains the speed ratio 64 80 100 150 200 250 350 400 500 700 1000)
	L	L	L
Length(mm)	180.0	226.0	268.0

ABR220 precision planetary gear outline drawing

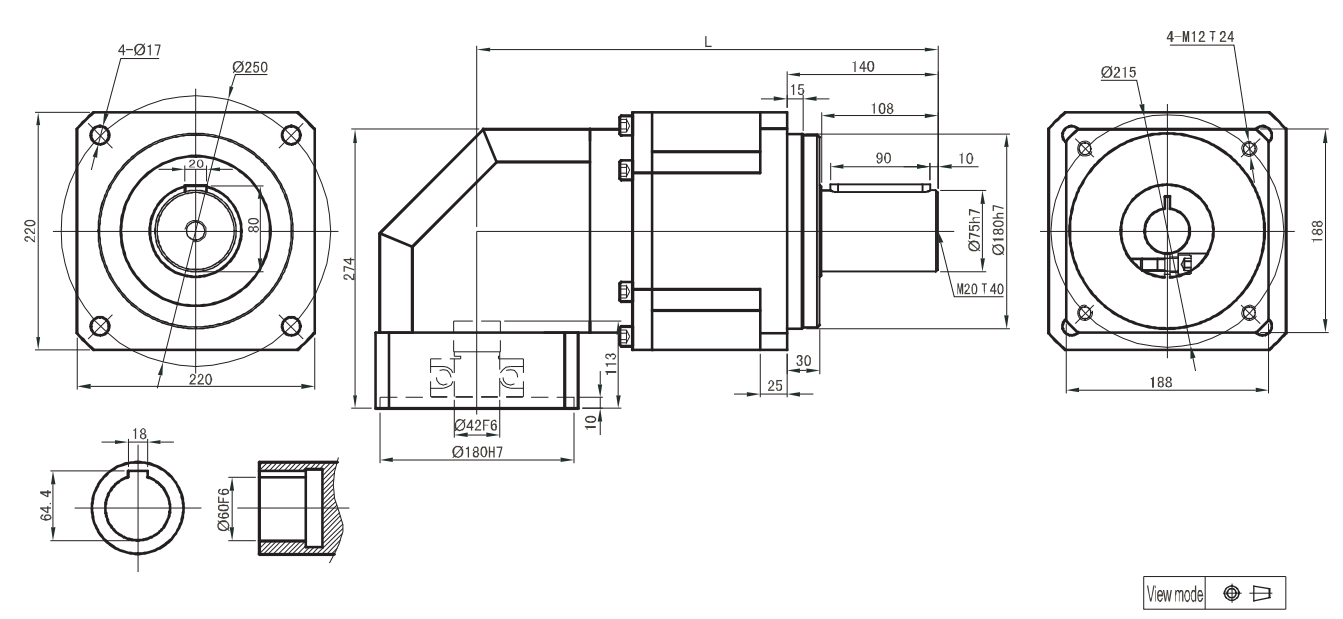

Stage	Stage 1 (Contains the speed ratio 3 4 5 7 10)	Stage 2 (Contains the speed ratio 9 15 20 25 30 40 50 70 100)	Stage 3 (Contains the speed ratio 64 80 100 150 200 250 350 400 500 700 1000)
	L	L	L
Length(mm)	287.0	332.0	398.0

V series precision spiral bevel gear box

V series precision spiral bevel gear box

一、Product introduction

- 1、The box shape has six surface, and can adapt to different range of installation
- 2、Commutator design, long service life, high carrying capacity, stable transmission, low noise, gear speed can be up to 40 meters / seconds, high transmission efficiency up to 94%~98%.
- 3、Spiral bevel gear is made of high quality low carbon alloy steel, carburizing quenching after grinding, and running, realize high precision hardened tooth surface closed transmission..
- 4、V series reducer has seven kinds of specifications, selection range, the output shaft in various forms, can meet the needs of a variety of occasions.
- 5、Can realize two transmission mode : deceleration and acceleration .

二、Model representation

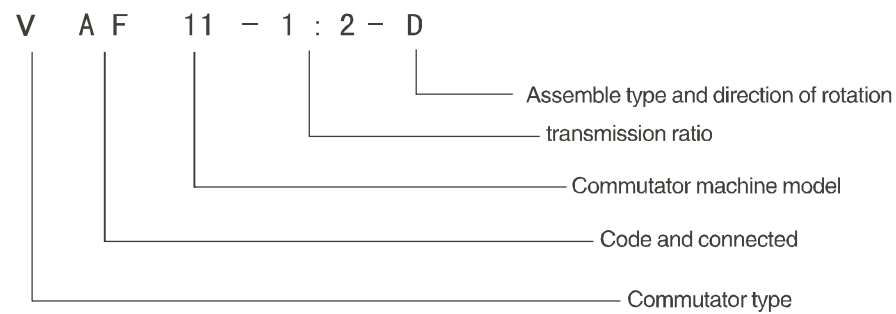

Code and connected

VS Input & output connection type is shaft connect	VA Input, output shaft extension type connection
VSF With the input flange, the output shaft extension type connection	VAF With the input flange, the output shaft extension type connection

三、Transmission ratio calculation

$$\text{Transmission ratio } i = \frac{\text{Input speed } n_1}{\text{Output speed } n_2} \quad \text{it's reducer when } i > 1; \text{ it's accelerator when } i < 1$$

四、The type selection

1. Formula selection: (1) $P_1 N = P_1 \times f$ (Every hour the start stop times of not more than 20 times)
- (2) $P_1 N = 1.2 \times P_1 \times f$ (The start stop times 21~60 times per hour)
- (3) $P_1 N \leq P_N$

Selection of power must be less than or equal to the allowable power

Type: $P_1 N$ type power, power P_1 the actual need, f coefficient, P_n as the allowable power.

2. Activity coefficient f

prime mover	Daily working time (hours)	Bearing type		
		uniform load	Medium impact load	Heavy shock load
Motor Gas turbine Hydraulic motor	3	0.8	1	1.5
	3~10	1	1.25	1.25
	10~24	1.25	1.5	2
Internal-combustion engine	3	1.25	1.5	2
	3~10	1.5	1.75	2.25
	10~24	1.25	2	2.5

五、Thermal power check

1. Calculation of thermal power: $P_{GN} = P_G \times f_1 \times f_2$

$$P_{GN} > P_1 \text{ (Natural cooling)}$$

$$P_{GN} > P_1 \text{ (Fan or oil cooling)}$$

Type: F_1 is the environment temperature coefficient, F_2 is coefficient of continuous work, P_G is commutator heat capacity, P_1 is the actual need of power, the heat capacity is calculated P_{GN} commutator.

2. Environmental temperature coefficient F_1

Ambient temperature °C	10	20	30	40	50
Coefficient F_1	1.2	1	0.87	0.75	0.64

3. Continuous working coefficient F_2

The work rate per hour %	100	80	60	40	20
f_2	1	1.2	1.4	1.6	1.8

六、Heat capacity P_G (cooling)

Transmission ratio	Box model						
i	09	11	14	17	21	24	28
1~5	4.5	6.5	11	15.5	24	31	44

七、General technical specification

1. Key and keyway size in accordance with the provisions of GB1095-79, GB1096-97, slot width tolerance: axis N9, the hub JS9.
2. Input and output shaft center hole with screw, specifications are as follows:

$D = 11 \sim 13 \text{ mm}$	Screw hole M3	$D > 24 \sim 30 \text{ mm}$	Screw hole M10
$> 13 \sim 16 \text{ mm}$	Screw hole M5	$> 30 \sim 38 \text{ mm}$	Screw hole M12
$> 16 \sim 21 \text{ mm}$	Screw hole M6	$> 38 \sim 50 \text{ mm}$	Screw hole M16
$> 21 \sim 24 \text{ mm}$	Screw hole M8	$> 50 \sim 85 \text{ mm}$	Screw hole M20

3. The dimensions in the figure, the input shaft, output shaft, the speed and the torque is permitted, the output shaft as the input shaft transmission.

V series precision spiral bevel gear box

八、 Selection example

Example: using spiral bevel gear commutator driven stirrer

A practical need power $P_1=28KW$, motor power $P_2=30KW$, speed $n_1=2000r/min$, transmission ratio $i=2$, commutator assembly form is D, working 8 hours a day, each time for 60% hours of continuous work, stop 6 times per hour, an ambient temperature of 30 °C.

Selection: the original motivation for the motor stirrer, medium impact load, working 8 hours a day, according to the use of the coefficient table:

$$f_1 = 1.25$$

Selection of power : $P_{IN}=P_1 \times f_1 = 28 \times 1.25 = 35KW$ (stop 6 times per hour)
 According to the allowable power: box type number 21, $P_N=52.4KW > 35KW$
 Thermal power: 21 check box, press $P_G=24KW$ heat capacity table
 According to the environmental temperature coefficient table: $f_1=0.87$
 According to the continuous working coefficient table: $f_2=1.4$

$$P_{GN}=24 \times 0.87 \times 1.4 = 29.2KW > 28KW$$

The natural cooling.

Selection type: VS 2 1 - 2 D

九、 Transmission ratio, speed input and the allowable input power

Transmission ratio i	Input speed n1 r/min	Output speed n2 r/min	Box model						
			09	11	14	17	21	24	28
The allowable input power PN (KW)									
1	2000	2000	7.55	13.8	29.9	49.2	84	111	188
	1500	1500	6	11	23.9	39.3	67.5	90.5	156
	1000	1000	4.3	7.85	17.2	28.8	50.5	68	115
	750	750	3.4	6.15	13.4	22.8	40.8	54.5	94.2
1.5	2000	1333	5.45	9.7	16.8	33.9	70	92.5	124
	1500	1000	4.3	7.75	13.5	27.2	56.5	75.5	103
	1000	667	3.05	5.45	9.7	19.6	41.2	55.5	75.5
	750	500	2.3	4.25	7.6	15.5	33	44.5	60.5
2	2000	1000	4.2	7.95	14.1	26.2	52.4	71.5	107
	1500	750	3.35	6.3	11.1	20.8	43.2	58.5	88
	1000	500	2.35	4.45	7.85	14.9	31.4	41.9	64.5
	750	375	1.8	3.45	6.2	11.6	25.2	33.8	51
3	2000	667	2.85	5.6	10.1	18.2	34.9	52.4	73
	1500	500	2.2	4.45	7.95	14.4	27.7	41.9	58.5
	1000	333	1.5	3.1	5.6	10.1	20	30.2	42.4
	750	250	1.2	2.4	4.4	7.8	15.7	23.6	33.5
4	2000	500	2.15	3.75	6.8	10.5	23.3	37.7	47.6
	1500	375	1.65	2.9	5.3	8.4	18.5	30.2	38.5
	1000	250	1.15	2	3.75	5.9	13.4	21.7	27.5
	750	188	0.87	1.55	2.95	4.55	10.4	17.1	21.7
5	2000	400	1.4	2.95	5.05	8.05	15.9	28.9	39.4
	1500	300	1.1	2.35	3.95	6.45	12.7	23.4	31.4
	1000	200	0.75	1.6	2.75	4.5	9	16.4	22.4
	750	150	0.58	1.25	2.1	3.45	6.95	13	17.7

Note: 1 this form of Xu for power value is decelerating, when demand growth, the allowable power value should take the transmission ratio.
 2. input and output shaft in the above range, please contact us.

V series precision spiral bevel gear box

VS09-VS28 (i=1~5) input and output shaft extension type connection

Dimensions

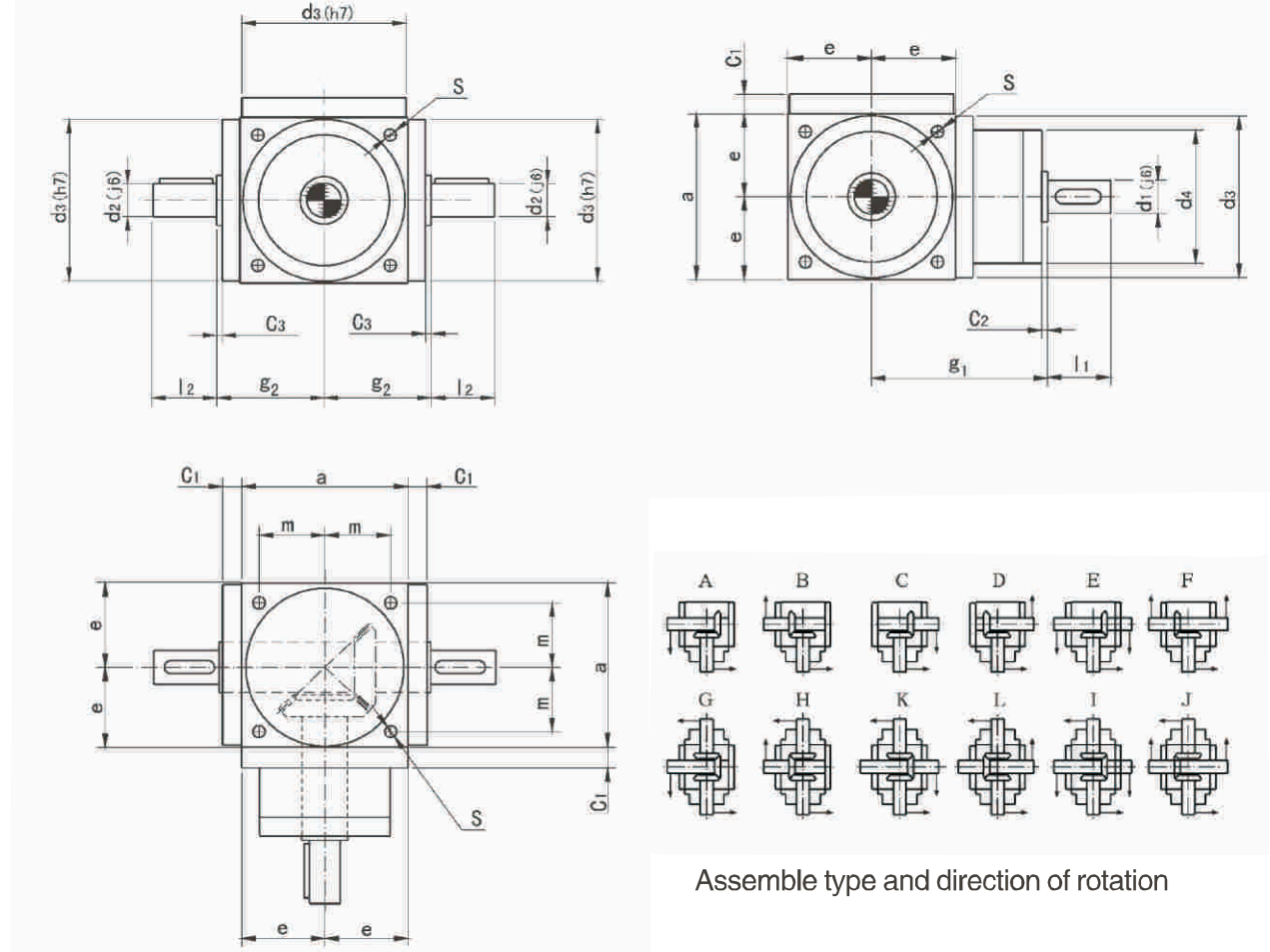

Assemble type and direction of rotation

model	a	C1	C2	C3	d2	l2	d3	e	g1	g2	m	S	i=1~2		i=3		i=4		i=5		i=1~3	i=4~5	weight Kg	oil L
													d1	l1	d1	l1	d1	l1	d1	l1				
09	90	12	2	2	18	35	88	45	97	59	36	M6	18	35	16	30	11	23	11	23	72	62	8	0.2
11	110	12	2	2	22	40	108	55	112	69	44	M8	22	40	20	35	16	30	14	25	81	72	15	0.3
14	140	15	2	2	32	50	135	70	157	84	55	M10	32	50	26	45	20	35	16	30	98	81	25	0.4
17	170	15	2	3	40	60	165	85	181	103	67	M12	40	60	32	50	26	45	22	40	118	98	35	1
21	210	20	2	2	45	70	205	105	230	130	85	M16	45	70	45	70	32	50	30	50	128	110	70	2
24	240	22	2	2	55	85	235	120	280	145	95	M16	55	85	55	85	38	55	35	55	138	120	95	2.5
28	280	22	2	2	60	110	275	140	280	160	110	M16	60	110	50	80	45	70	42	70	150	135	135	3

V series precision spiral bevel gear box

VA09-VA28 input shaft, output shaft extension type connection

Dimensions

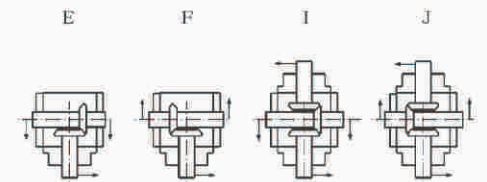
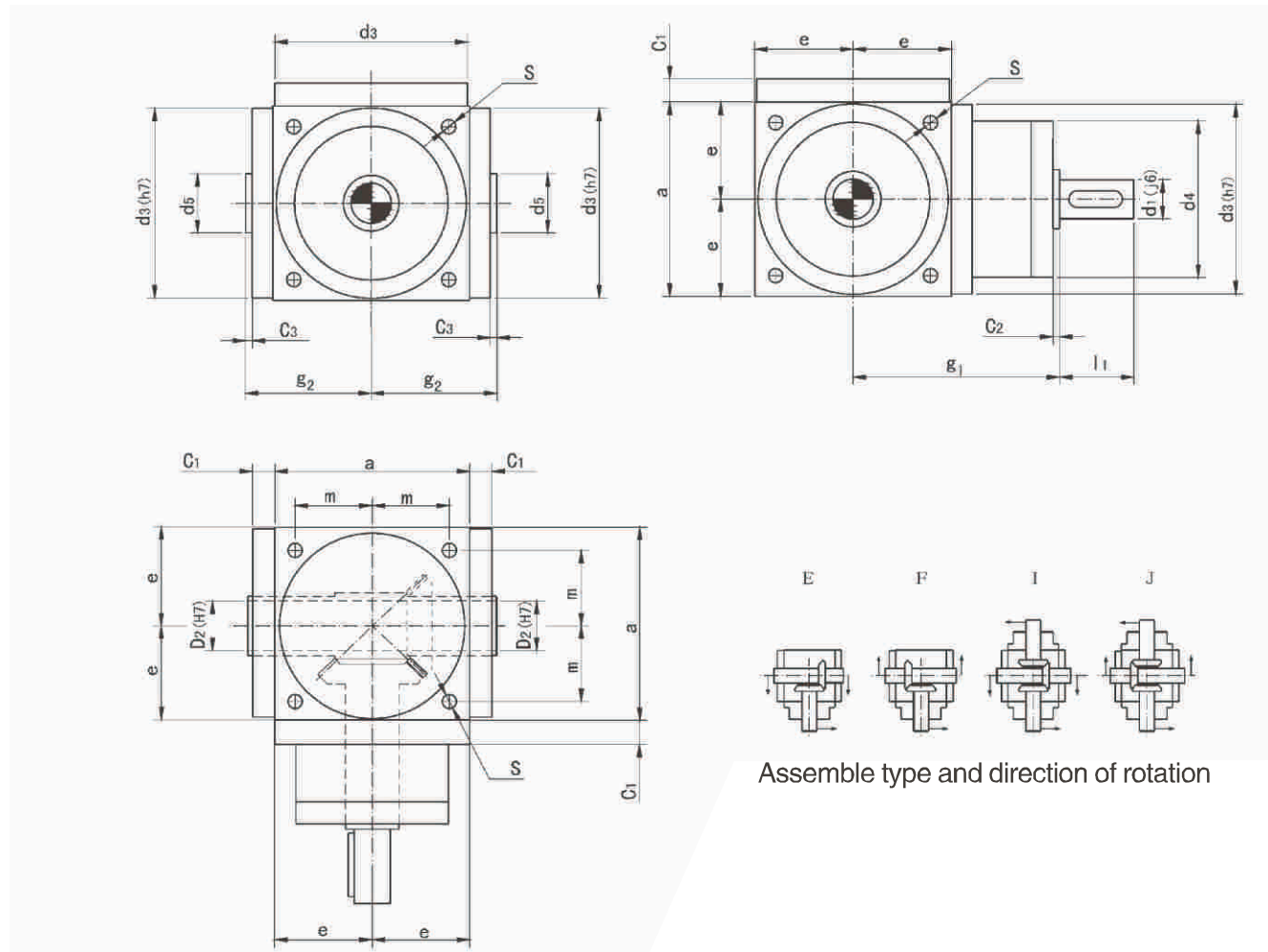

Assemble type and direction of rotation

model	a	C1	C2	C3	D2	d5	d3	e	g1	g2	m	S	i=1~2		i=3		i=4		i=5		i=1~3	i=4~5	weight	oil
													d1	l1	d1	l1	d1	l1	d1	l1				
09	90	12	2	2	16	25	88	45	97	59	36	M6	18	35	16	30	11	23	11	23	72	62	8	0.2
11	110	12	2	2	22	35	108	55	112	69	44	M8	22	40	20	35	16	30	14	25	81	72	15	0.3
14	140	15	2	2	28	45	135	70	157	87	55	M10	32	50	26	45	20	35	16	30	98	81	25	0.4
17	170	15	2	3	38	55	165	85	181	103	67	M12	40	60	32	50	26	45	22	40	118	98	35	1
21	210	20	2	2	45	65	205	105	230	130	85	M16	45	70	45	70	32	50	30	50	128	110	70	2
24	240	22	2	2	55	75	235	120	280	145	95	M16	55	85	48	85	38	55	35	55	138	120	95	2.5
28	280	22	2	2	60	85	275	140	280	160	110	M16	60	110	50	80	45	70	42	70	150	135	135	3

V series precision spiral bevel gear box

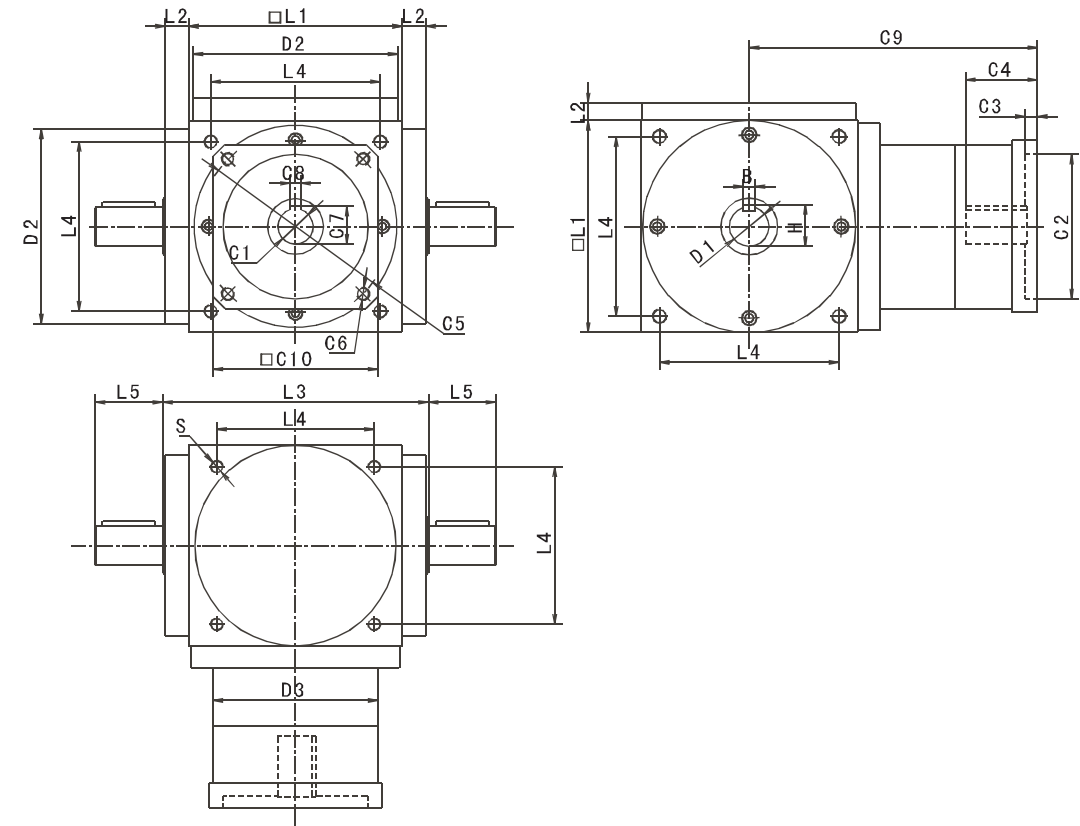

model	VSF09	VSF11	VSF14	VSF17	VSF21	VSF24	VSF28
L1	90	110	140	170	210	240	280
L2	12	12	12	15	18	18	18
L3	118	138	168	206	250	280	320
L4	72	88	110	134	170	190	220
L5	35	40	50	60	70	85	110
S	M6	M8	M10	M12	M16	M16	M16
D1 (j6)	18	22	32	40	45	55	60
D2 (h7)	88	108	135	165	205	235	275
D3	86	82	104	128	160	170	190
H	20.5	24.5	35	43	48.5	59	64
B	5	6	8	10	12	14	16
C1*	14	19	22	35	42	48	55
C2*	50	70	110	114.3	180	200	230
C3*	5	5	10	10	10	10	10
C4*	35	45	65	85	98	98	110
C5*	70	90	145	200	215	235	265
C6*	M5	M6	M8	M12	M12	M12	M12
C7*	16.3	21.8	24.8	38.3	45.3	51.8	59.3
C8*	5	6	6	10	12	14	16
C9*	110	130	170	215	245	265	315
C10*	60	90	130	180	200	200	250

C1*-C10*: commonly used for special types of input interface, please contact the company.

V series precision spiral bevel gear box

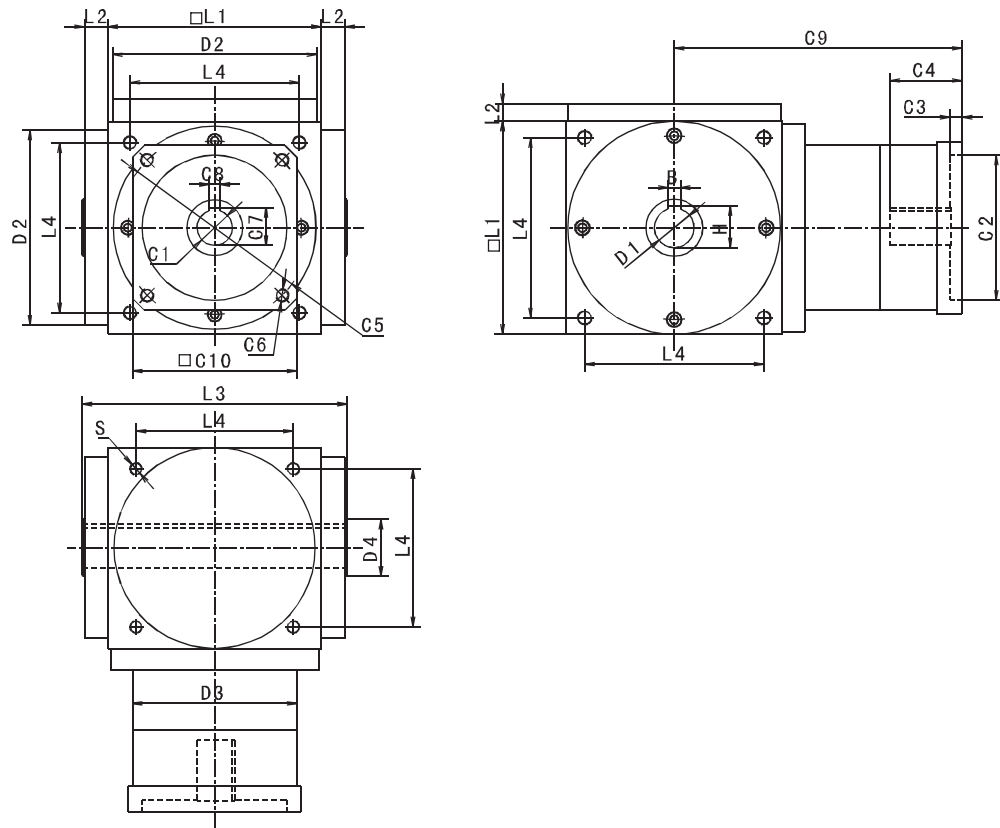

model	VAF09	VAF11	VAF14	VAF17	VAF21	VAF24	VAF28
L1	90	110	140	170	210	240	280
L2	12	12	12	15	18	18	18
L3	118	138	168	206	250	280	320
L4	72	88	110	134	170	190	220
S	M6	M8	M10	M12	M16	M16	M16
D1 (j6)	16	22	28	38	45	55	60
D2 (h7)	88	108	135	165	205	235	275
D3	86	82	104	128	160	170	190
D4	25	35	45	55	65	75	85
H	18.3	25	31.3	41.3	48.5	59	64
B	5	6	8	10	12	14	16
C1*	14	19	22	35	42	48	55
C2*	50	70	110	114.3	180	200	230
C3*	5	5	10	10	10	10	10
C4*	35	45	65	85	98	98	110
C5*	70	90	145	200	215	235	265
C6*	M5	M6	M8	M12	M12	M12	M12
C7*	16.3	21.8	24.8	38.3	45.3	51.8	59.3
C8*	5	6	6	10	12	14	16
C9*	110	130	170	215	245	265	315
C10*	60	90	130	180	200	200	250

C1*-C10*: commonly used for special types of input interface, please contact the company.

Reducer installation

The correct installation, use and maintenance of the reducer, is an important link to ensure the normal operation of machinery and equipment. Therefore, before you install reducer, please strictly in accordance with the following installation related matters, serious assembly.

1. Connected with the original motivation:

First Step Confirm the motor and reducer is intact before installation, and strictly check the size of each part of motor and the speed reducer is connected is matched, mainly refers to the convex table size and speed reducer groove size motor and tolerances (Fig. 1).

The second step The dustproof reducer flange lateral process hole on the cover, adjust the input shaft of the speed reducer elastic clamping device so that the fastening bolt and the process holes, insert the inner six angle wrench (Figure 2). This procedure is suitable for connecting the elastic clamping mechanism.

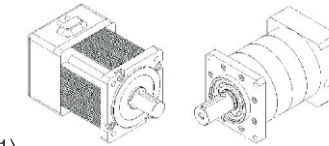

(Figure 1)

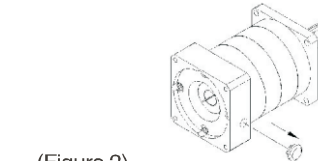

(Figure 2)

The third step Take the motor shaft key (key connection slightly), connecting part of the output shaft of the motor, the positioning boss and reducer anti rust oil gasoline or zinc sodium water to wipe the net (Figure 3), its purpose is to ensure that the close connections and the flexibility of the operation, and prevent unnecessary wear and tear, the electric machine and reducer natural join. The connection must ensure that the output shaft of the speed reducer and motor input shaft coaxial line, and the two outer flanges parallel, if the shaft is not consistent, will cause the motor shaft breakage or reducer gear wear. In addition, when in installation, prohibited the use of hammer, strike, to prevent axial and radial force is too large damage to the bearing or gear (Figure 4).

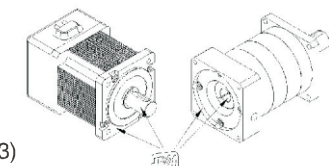

(Figure 3)

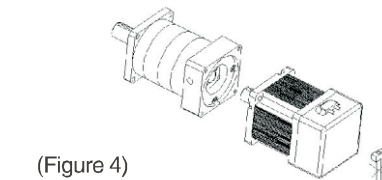

(Figure 4)

The fourth step When connect the motor and reducer, please ensure the motor shaft keyway with the fastening bolt upright. In order to ensure the uniform stress, please make the installation bolt rotating arbitrary diagonal position, but don't tighten, then screw on the other two diagonal position of the mounting bolts finally by tightening the four mounting bolt (Figure 5). Finally, tighten the fastening bolt. High precision fastening bolts with torque wrench according to fixed torque data indicated (see Table 1) were fixed and examined (Figure 6).

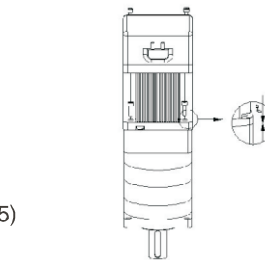

(Figure 5)

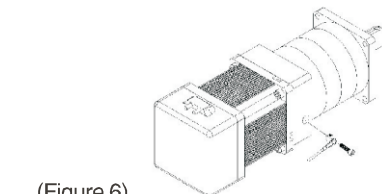

(Figure 6)

(Table 1)

Screw size	Six hexagon head size	Magnitude of 10.9 screw locking torque		Magnitude of 12.9 screw locking torque	
	(mm)	(Nm)	(In-lbs)	(Nm)	(In-lbs)
M 3*0.5P	2.5	1.8	16	2.1	19
M 4*0.7P	3.0	4.1	37	4.9	44
M 5*0.8P	4.0	8.2	73	9.8	87
M 6*1P	5.0	14	124	17	151
M 8*1.25P	6.0	34	302	41	364
M 10*1.5P	8.0	67	594	80	709
M 12*1.75P	10.0	116	1028	139	1232
M 14*2P	12.0	186	1648	223	1976
M 16*2P	14.0	286	2534	343	3038

2. Connecting with the working machine:

Installation and working machine, attention should be paid to the center axis of transmission, the error may not use the compensation amount is greater than all. On the good service life can be prolonged, and the transmission efficiency is obtained. Install the transmission on the output shaft, are not allowed to use a hammer percussion, usually with inner screw assembly jig and shaft ends, bolt driving piece pressing, damaged or is likely to cause of internal parts of reducer. Best not to use steel fixed coupling, because this kind of coupling installation is improper, will cause unnecessary loads, resulting in bearing early damage, even causing the output shaft fracture.

3. Speed reducer fixed:

Reducer should be firmly installed in the steady reference or support, and the circulation of cooling air flow. Reference or support is not reliable, operation will cause vibration and noise, and urges the bearing and gear damage. When the drive coupling protrusion or a gear, sprocket drive, should be considered with the protection device. After installation, should be installed according to the comprehensive examination order position accuracy, reliability of the fasteners, pressed, after installation should be flexible rotation. Reducer loading is required when the load test run, time shall not be less than 2 hours. Operation should be smooth, no impact, vibration, noise and oil leakage phenomenon, found abnormal should be excluded. If the ambient temperature is too high or too low, the need to change the grease.

4. Installation:

Any installation

